

# Power Take-Offs Owner's Manual

Ford "F" Series

247, 249, 249V, 272-FORD Series



ENGINEERING YOUR SUCCESS.



### **WARNING – User Responsibility**

FAILURE OR IMPROPER SELECTION OR IMPROPER USE OF THE PRODUCTS DESCRIBED HEREIN OR RELATED ITEMS CAN CAUSE DEATH, PERSONAL INJURY AND PROPERTY DAMAGE.

This document and other information from Parker Hannifin Corporation, its subsidiaries and authorized distributors provide product or system options for further investigation by users having technical expertise.

The user, through its own analysis and testing, is solely responsible for making the final selection of the system and components and assuring that all performance, endurance, maintenance, safety and warning requirements of the application are met. The user must analyze all aspects of the application, follow applicable industry standards, and follow the information concerning the product in the current product catalog and in any other materials provided from Parker or its subsidiaries or authorized distributors.

To the extent that Parker or its subsidiaries or authorized distributors provide component or system options based upon data or specifications provided by the user, the user is responsible for determining that such data and specifications are suitable and sufficient for all applications and reasonably foreseeable uses of the components or systems.

### **Offer of Sale**

The items described in this document are hereby offered for sale by Parker Hannifin Corporation, its subsidiaries or its authorized distributors. This offer and its acceptance are governed by the provisions stated in the "Offer of Sale".



**WARNING:** This product can expose you to chemicals including Lead and Lead Compounds, and Di(2-ethylhexyl)phthalate (DEHP) which are known to the State of California to cause cancer and birth defects or other reproductive harm. For more information go to [www.P65Warnings.ca.gov](http://www.P65Warnings.ca.gov)

© Copyright 2025, Parker Hannifin Corporation, All Rights Reserved

**Table of Contents**

**General Information**

Foreword ..... 1  
 Safety Information ..... 1-3  
 PTO Safety Label Instructions ..... 3  
 Pump Bracketing Best Practices ..... 4-5  
 Function of Auxiliary Power Shafts ..... 6  
 Spicer® Universal Joint Engineering Data ..... 7  
 PTO Shifting Procedure & Precautions ..... 8  
 PTO Maintenance ..... 9

**Transmission Overview**

**TorqShift® 5R110 Transmission**

Stationary Elevated Idle Control (SEIC) – 6.7L Diesel and 6.8L Gas ..... 10-12

**TorqShift® 6R140 Transmission**

Stationary Elevated Idle Control (SEIC) – 6.7L Diesel ..... 13-15  
 Stationary Elevated Idle Control (SEIC) – 6.8L Gas ..... 16-18  
 Stationary Elevated Idle Control (SEIC) – 6.7L Diesel (MY2020-MY2025)/7.3L Gas ..... 19-25

**249/249V Series Installation Instructions**

Super Duty F-250-F-550 (MY2011-2019) 6.7L Diesel In-Cab PTO Switch Installation  
 Medium Duty F-650/F-750 (MY2016-MY2025) 6.7L Diesel In-Cab PTO Switch Installation ..... 28-29  
 Super Duty F-250-F-550 (MY2017-MY2019) 6.2L/6.8L Gas In-Cab PTO Switch Installation  
 Medium Duty F-650/F-750 (MY2013-MY2019) 6.8L Gas In-Cab PTO Switch Installation  
 Medium Duty F-650/F-750 (MY2020-MY2025) 7.3L Gas In-Cab PTO Switch Installation ..... 30-31  
 Mounting the PTO ..... 32-37  
 Medium Duty F-650 (MY2013-MY2015) 6.8L Gas 249G Special Installation Instructions ..... 38  
 Potentiometer Settings ..... 38

**Installation Sketches**

Wiring Installation (Shift Option B) – Super Duty F-250-F-550 (MY2011-MY2019) w/o EOC 6.7L Diesel  
 Medium Duty F-650/F-750 (MY2016-MY2025) w/o EOC 6.7L Diesel (249F) (SK-490 Rev G) ..... 39  
 Wiring Installation Chart (Shift Option B) – Super Duty F-250-F-550 (MY2011-MY2019) w/o EOC 6.7L Diesel  
 Medium Duty F-650/F-750 (MY2016-MY2025) w/o EOC 6.7L Diesel (249F) (SK-490 Rev G) ..... 40  
 Wiring Installation (Shift Option B) – Medium Duty F-650 (MY2013-MY2015)  
 w/o EOC 6.8L Gas (249G) (SK-560 Rev D) ..... 41  
 Wiring Installation Chart (Shift Option B) – Medium Duty F-650 (MY2013-MY2015)  
 w/o EOC 6.8L Gas (249G) (SK-560 Rev D) ..... 42  
 Wiring Installation (Shift Option B) – Super Duty F-250-F-550 (MY2017-MY2019) w/o EOC 6.2/6.8L Gas  
 Medium Duty F-650/F-750 (MY2016-MY2019) w/o EOC 6.8L Gas (249H)  
 Medium Duty F-650/F-750 (MY2020-MY2025) w/o EOC 7.3L Gas (SK-490 Rev G) ..... 43  
 Wiring Installation Chart (Shift Option B) – Super Duty F-250-F-550 (MY2017-MY2019) w/o EOC 6.2/6.8L Gas  
 Medium Duty F-650/F-750 (MY2016-MY2019) w/o EOC 6.8L Gas (249H)  
 Medium Duty F-650/F-750 (MY2020-MY2025) w/o EOC 7.3L Gas (SK-490 Rev G) ..... 44  
 Wiring Installation (Shift Option K) – Super Duty F-250-F-550 (MY2011-MY2019) w/ EOC 6.7L Diesel  
 Medium Duty F-650/F-750 (MY2016-MY2025) w/ EOC 6.7L Diesel (249F)  
 Super Duty F-250-F-550 (MY2017-MY2019) w/ EOC 6.8L Gas  
 Medium Duty F-650/F-750 (MY2017-MY2019) w/ EOC 6.8L Gas (249H)  
 Medium Duty F-650/F-750 (MY2020-MY2025) w/ EOC 7.3L Gas (SK-489 Rev H) ..... 45  
 Wiring Installation Chart (Shift Option K) (249F)  
 Super Duty F-250-F-550 (MY2011-MY2019) w/ EOC 6.7L Diesel  
 Medium Duty F-650/F-750 (MY2016-MY2025) w/ EOC 6.7L Diesel ..... 46  
 Wiring Installation Chart (Shift Option K) (249H)  
 Super Duty F-250-F-550 (MY2017-MY2019) w/ EOC 6.8L Gas  
 Medium Duty F-650/F-750 (MY2017-MY2019) w/ EOC 6.8L Gas  
 Medium Duty F-650/F-750 (MY2020-MY2025) w/ EOC 7.3L Gas (SK-489 Rev H) ..... 46

Continued on Next Page

**Table of Contents**

<b>247/249 Series Pump Information</b>	
Mounting CGP-P11 Pumps to PTO .....	47
<b>249V Series Vane Pump Information</b>	
Start-Up Instructions (249V Series Only).....	48-55
Hydraulic Fluid Recommendations .....	50-51
Pump & Cartridge Breakdown Drawing.....	52
Pump Cartridge Replacement.....	53-55
<b>249V Series Vane Pump Troubleshooting</b>	
Vane Pump Troubleshooting Guide .....	56-59
<b>272-FORD Series Installation Instructions</b>	
Mounting the PTO.....	62-63
<b>Installation Sketches</b>	
Wiring Installation (Shift Option B) – Medium Duty F-650/F-750 (MY2016-MY2025) 6.7L Diesel	
Medium Duty F-650/F-750 (MY2016-MY2019) 6.8L Gas w/o EOC (272F & 272H)	
Medium Duty F-650/F-750 (MY2020-MY2025) 7.3L Gas w/o EOC (SK-611 Rev B) .....	64
Wiring Installation Chart (Shift Option B) – Medium Duty F-650/F-750 (MY2016-MY2025) 6.7L Diesel w/o EOC (272F)	
Medium Duty F-650/F-750 (MY2016-MY2019) 6.8L Gas w/o EOC (272H)	
Medium Duty F-650/F-750 (MY2020-MY2025) 7.3L Gas w/o EOC (272H) (SK-611 Rev B) .....	65
Wiring Installation (Shift Option K) – Medium Duty F-650/F-750 (MY2016-MY2025) 6.7L Diesel	
Medium Duty F-650/F-750 (MY2017-MY2019) 6.8L Gas w/ EOC (272F & 272H)	
Medium Duty F-650/F-750 (MY2020-MY2025) 7.3L Gas w/ EOC (SK-612).....	66
Wiring Installation Chart (Shift Option K) – Medium Duty F-650/F-750 (MY2016-MY2025) 6.7L Diesel w/ EOC (272F)	
Medium Duty F-650/F-750 (MY2017-MY2019) 6.8L Gas w/ EOC (272H)	
Medium Duty F-650/F-750 (MY2020-MY2025) 7.3L Gas w/ EOC (272H) (SK-612) .....	67
Wiring Installation (Shift Option B) – Medium Duty F-650 (MY2012-MY2015) 6.8L Gas	
w/o EOC (272J) (SK-613 Rev A).....	68
Wiring Installation Chart (Shift Option B) – Medium Duty F-650 (MY2012-MY2015) 6.8L Gas	
w/o EOC (272J) (SK-613 Rev A).....	69
<b>247 Series Installation Instructions</b>	
In-Cab PTO Switch Installation.....	72-73
Ford LCF/International CF Overview (MY2006-MY2010) .....	73
Mounting the PTO.....	74-77
Potentiometer Settings.....	77
<b>Installation Sketches</b>	
Wiring Installation (Shift Option B) – Super Duty F-250-F-550 (MY2005-MY2010) Diesel/Gas w/o EOC	
Super Duty F-250-F-550 (MY2011-MY2016) 6.8L Gas w/o EOC	
Super Duty F-250-F-550 (MY2006-MY2010) LCF w/o EOC (SK-448 Rev C) .....	78
Wiring Installation Chart (Shift Option B) – w/o EOC (SK-448 Rev C).....	79
Wiring Installation (Shift Option K) – Super Duty F-250-F-550 (MY2005-MY2016) 6.8L Gas w/ EOC	
Super Duty F-250-F-550 (MY2005-MY2010) 6.0L/6.4L Diesel w/ EOC	
LCF (MY2005-MY2009) w/ EOC (SK-474 Rev A).....	80
Wiring Installation Chart (Shift Option K) – w/ EOC (SK-474 Rev A) .....	81
<b>Appendix</b>	
Potentiometer Settings.....	82-84
Installing the PTO Heat Shield – GAS Engines ONLY (After April 2017) .....	85
TorqShift® Bracket – Field Modification MY2005.....	86
Ford Shifter & Bracket Removal and Installation .....	87-90
Chelsea – Ford Wiring Chart – Diesel .....	91
Chelsea – Ford Wiring Chart – Gas .....	92
Offer of Sale .....	93-95

## General Information

---

### Foreword

This booklet will provide you with information on correct installation of Chelsea® Power Take-Offs (PTOs). Proper installation and setup procedures can help you get additional and more profitable hours from your truck equipment and components.

It is important that you be sure that you are getting the right transmission and PTO combination when you order a new truck. A mismatched transmission and PTO combination can result in unsatisfactory performance of your auxiliary power system from the start.

If you have questions regarding correct PTO and transmission combination, please contact your local Chelsea® representative. They can help you select the properly matched components to ensure correct and efficient applications.

### Safety Information

These instructions are intended for the safety of the system designer, installer, operator, and supporting personnel. If you have any additional questions after reading the instructions below, please reach out to your local Chelsea representative.

#### General Safety Information

##### To prevent injury to yourself and/or damage to the equipment:

- Carefully read all owner's manuals, service manuals, and/or other instructions.
- Always follow procedures using proper tools and safety equipment.
- Ensure proper training is received prior to attempting to install equipment.
- Always block any raised or moving device that may injure a person working on or under a vehicle.
- Never work alone while under a vehicle, repairing equipment, or maintaining equipment.
- Always use proper components in applications for which they are approved.
- Never use worn-out or damaged components.
- Never operate the controls of the PTO or other driven equipment from any position that could result in getting caught in the moving machinery.

#### Proper Matching of PTO



**WARNING:** A Power Take-Off must be properly matched to the vehicle transmission and to the auxiliary equipment being powered. An improperly matched Power Take-Off could cause severe damage to the vehicle transmission, the auxiliary driveshaft, and/or to the auxiliary equipment being powered. **Damaged components or equipment could malfunction causing serious personal injury to the vehicle operator or to others nearby.**

##### To avoid personal injury and/or equipment damage:

- Always refer to Chelsea's catalogs, literature, and owner's manuals.
- Follow Chelsea's recommendations when selecting, installing, repairing, or operating a PTO.
- Never attempt to use a PTO that is not specifically recommended by Chelsea for the vehicle, transmission, and application.
- Always match the PTO's specified output capabilities with the requirements of the equipment to be powered.
- Never exceed the maximum speed listed in Chelsea's Applications Catalog.



This symbol warns of possible personal injury.

## General Information

### Safety Information (Cont'd)

#### Cold Weather Operation of PowerShift PTO

 **WARNING:** During extreme cold weather operation [32°F (0°C) and lower], a disengaged PowerShift Power Take-Off can momentarily transmit high torque that will cause unexpected output shaft rotation. This is caused by the high viscosity of the transmission oil when it is extremely cold. As slippage occurs between the Power Take-Off clutch plates, the oil will rapidly heat up, and the viscous drag will quickly decrease.

The rotation of the PTO's output shaft could cause unexpected movement of the driven equipment resulting in serious personal injury, death, or equipment damage.

#### To avoid personal injury or equipment damage:

- Driven equipment must have separate controls.
- The driven equipment must be left in the disengaged position when not in operation.
- Do not operate the driven equipment until the vehicle is allowed to warm up.

#### Rotating Auxiliary Driveshafts



- Rotating auxiliary driveshafts can cause serious injury or death by snagging clothes, skin, hair, hands etc.
- Do not go under the vehicle when the engine is running.
- Do not work on or near an exposed shaft when the engine is running.
- Shut off the engine before working on the PTO or driven equipment.
- Exposed rotating driveshafts must be guarded.

#### Guarding Auxiliary Driveshafts

 **WARNING:** We strongly recommend that a Power Take-Off and a directly mounted pump be used to eliminate the auxiliary driveshaft whenever possible. If an auxiliary driveshaft is used and remains exposed after installation, it is the responsibility of the vehicle designer to specify guard(s) and PTO installer to install guard(s).

#### Using Set Screws

 **WARNING:** Auxiliary driveshafts may be installed with either recessed or protruding set screws. If you choose a square head set screw, you should be aware that it will protrude above the hub of the yoke and may be a point where clothes, skin, hair, hands etc., could be snagged. A socket head set screw, which may not protrude above the hub of the yoke, does not permit the same amount of torquing as does a square head set screw. Also, a square head set screw, if used with a lock wire, will prevent loosening of the screw caused by vibration. Regardless of the choice made with respect to a set screw, an exposed rotating auxiliary driveshaft must be guarded.

#### Important: Safety Information and Owner's Manual

 **WARNING:** Chelsea Power Take-Offs are packaged with warning labels, safety information decals, instructions, and an owner's manual. These items are located in the envelope with the PTO mounting gaskets. Also, safety information and installation instructions are packaged with some individual parts and kits. Be sure to read the owner's manual and safety information before installing or operating the PTO. Always install the safety information decals according to the instructions provided. Place the owner's manual in the vehicle glove compartment.

 This symbol warns of possible personal injury.

**General Information**

**Safety Information (Cont'd)**

**! WARNING: Operating the PTO with the Vehicle in Motion**

Some Power Take-Offs may be operated when the vehicle is in motion. PTOs must be properly selected to operate at highway speeds, correctly matched to the vehicle's transmission, as well as the requirements of the driven equipment.

If in doubt about the PTO specifications and capabilities, avoid operating the PTO when the vehicle is in motion. Improper application and/or operation can cause serious personal injury as well as premature failure of the vehicle, driven equipment, and PTO.

Always remember to disengage the PTO when the driven equipment is not in operation.

**PTO Safety Label Instructions**

1. The two black and orange on white 5" x 7" pressure sensitive vinyl labels (PN 379274) must be placed one on each side of the vehicle in a position that would be **HIGHLY** visible to anyone that would go under the truck near the PTO rotating shaft. If the vehicle is to be painted after these labels are installed, cover them with two blank masking covers. Remove the masking covers after painting.
2. Place the one black and orange on white 3.5" x 5" pressure sensitive vinyl label (PN 379275) on the sun visor nearest the operator of the vehicle.
3. Place the one red and white with black lettering 3.5" x 7" pressure sensitive vinyl label (PN 379915) on the sun visor next to the above label (PN 379275).
4. Place the one white and black heavy-duty card (PN 379276) in the vehicle glove box in a position highly visible to the operator. For example, try to place this card on top of whatever may be in the glove box.

If you require labels, please order part number 328946X at no charge from your local Chelsea representative or send request direct to:

**Parker-Hannifin Corporation**  
 Chelsea Products Division  
 8225 Hacks Cross Road  
 Olive Branch, MS 38654

Phone: +1 (662) 895-1011  
 Email: [chd\\_support@support.parker.com](mailto:chd_support@support.parker.com)

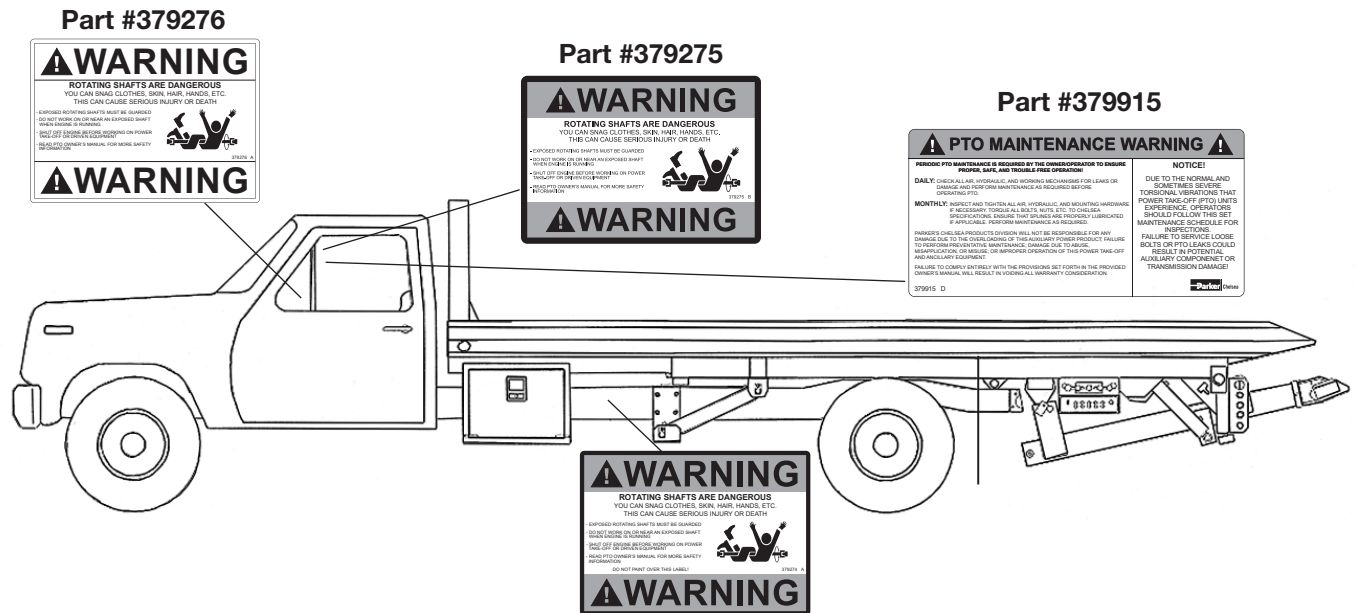

**! This symbol warns of possible personal injury.**

## General Information

### Pump Bracketing Best Practices

With changes in emissions standards, truck systems are experiencing more vibration and vibration related issues. Due to the changes, Parker Chelsea finds it necessary to discuss the importance of pump bracketing and the effects it can have on the mounted PTO. Parker Chelsea has made updates to the pump bracketing support guidelines listed in all PTO Owner's Manuals. This bulletin will discuss the importance of bracketing and the best practices to keep in mind when mounting a pump.

**Please note, due to the high variance of applications and the increasing severity of vibration found in modern diesel engines Parker Chelsea's pump bracketing best practices cannot consider all factors affecting the PTO and Pump bracketing. Please use the following information as a GUIDELINE ONLY when installing pump bracketing.**

#### Potential causes of bracket failures that can damage a PTO and/or Pump:

- Excessive preload from poor bracket design, fabrication, and installation.
- Excessive vibration from the vehicle's normal driving operation leading to high loads on the PTO bolts.
- Torque spikes from extreme vibration could be intense enough to break bolts in the bracketing. The worst cases occur while the truck is operating at highway speeds.

**! WARNING:** In addition to the conditions listed above, Chelsea requires the use of support brackets in all applications to ensure the Maximum Bending Moment (MBM) of the PTO and pump assembly is not exceeded. Exceeding the MBM can result in damage to PTO, transmission, driven equipment, and/or personnel. It is the responsibility of the installer to ensure that adequate support is implemented. All applications are unique and it is important to consider all parameters in designing a proper support bracket.

Use **CAUTION** to ensure the support bracket does not pre-load PTO and pump mounting. Prior to mounting, pumps must be fully supported by a jack until it is properly secured with support bracket(s). This will ensure the PTO is not being stressed by the bracket. Brackets must be designed to adequately eliminate deflections from weight, vibration, and truck movements.

#### PTO warranty will be voided if support brackets are not used when one of the following conditions apply:

- Combined weight of the pump, fittings, hoses, and oil exceeds 40 lbs [18.14 kg]
- Combined length of the PTO and pump is greater than 18 inches [45.72 cm]
- Pumps should have a support bracket when mounted onto a on a non-extended shaft PTO
- Extended Shaft PTOs: Please see applicable owner's manual for additional guidance

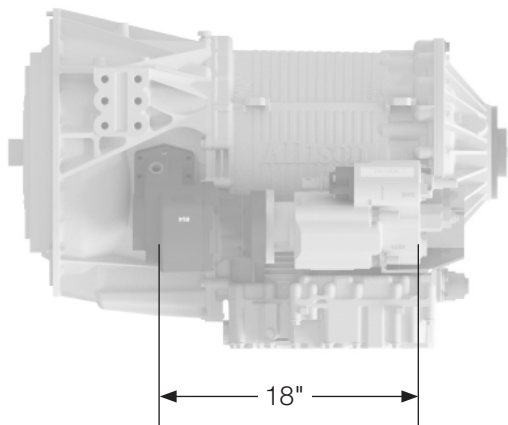

To ensure proper bracketing, brackets must attach at two or more transmission bolt locations as well as two or more pump (bolt) locations. Please reach out to your transmission manufacturer for proper bracket mounting locations.

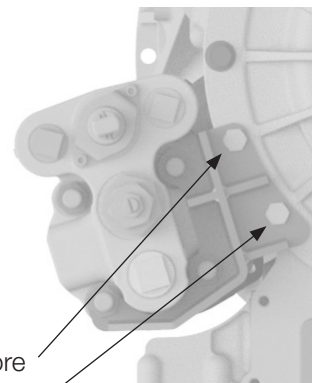

**! This symbol warns of possible personal injury.**

General Information

**Pump Bracketing Best Practices (Cont'd)**

An installed PTO/Pump bracket needs to be properly aligned. Misalignment in the X direction (**Fig. 1**) is substantially more impactful than misalignment in the Y or Z direction (**Fig. 2**). To prevent this, installing a fixture-built bracket is preferred. This allows the PTO/Pump to be installed prior to making the final welds on the bracket.

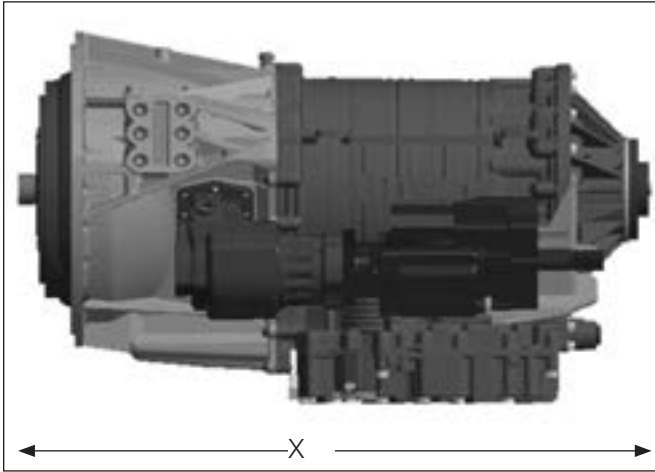

Figure 1

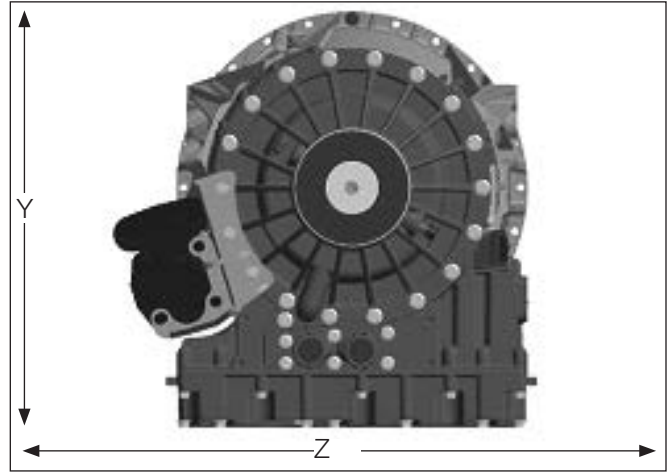
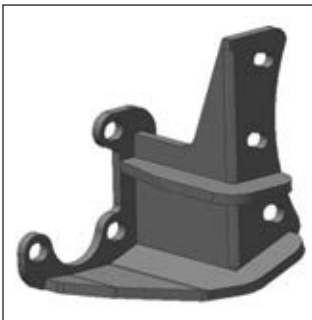

Figure 2

- The PTO/Pump should be treated as engine mounted components and installed per the engine manufacturer's published guidelines for engine mounted components when applicable.
- For proper bracketing, attach the bracket at two or more transmission bolt locations and two or more pump locations. Whenever possible, three attachment points in either (or both) locations is suggested. Please contact the transmission manufacturer for proper bracket mounting locations.
- Brackets should contain at least one gusset, preferably two. The gussets should be 3/8" thick and at least 1" deep. 3/8" steel is suggested particularly with gussets and in areas with reduced cross section.
- Please refer to the transmission and pump manufacturer's approved pump bracket support locations.



These best practices should be followed for optimal results. Please note, each bracketing situation is different so this bulletin must only be used as a guideline. For further bracketing assistance please refer to your PTO Owner's Manual or contact your Chelsea PTO representative for questions.

**If you have any technical questions, contact us at:**

**Phone: +1 (662) 895-1011**

**Email: [chd\\_support@support.parker.com](mailto:chd_support@support.parker.com)**

**General Information**

**Function of Auxiliary Power Shafts**

An auxiliary power shaft transmits torque from the power source to the driven accessory. The shaft must be capable of transmitting the maximum torque and RPM required of the accessory, plus any shock loads that develop.

An auxiliary power shaft operates through constantly relative angles between the power source and the driven accessory. Therefore, the length of the auxiliary power shaft must be capable of changing while transmitting torque. This length change, commonly called slip movement, is caused by movement of the power train due to torque reactions and chassis deflections.

Joint operating angles are very important in an auxiliary power joint application. In many cases, the longevity of a joint is dependent on the operating angles in the chart below.

<b>SPICER® UNIVERSAL JOINT OPERATING ANGLES</b>			
<b>Prop. Shaft RPM</b>	<b>Max. Normal Operating Angle</b>	<b>Prop. Shaft RPM</b>	<b>Max. Normal Operating Angle</b>
3000	5° 50'	1500	11° 30'
2500	7° 00'	1000	11° 30'
2000	8° 40'	500	11° 30'

The operating angles provided above are based on angular acceleration of 100 RAD/SEC<sup>2</sup>.  
**NOTE:** This information is limited to 1000 through 1310 series applications. Please contact your driveline specialist for applications requiring a series larger than 1310.

 **WARNING:** Direct customer to driveline manufacturer specifications.

**Determining Shaft Type**

- 1) Solid or tubular?
  - a) In applications requiring more than 1000 RPM or where the application necessitates a highly balanced auxiliary power shaft, a tubular shaft should be used.
  - b) Spicer's solid shaft auxiliary power joints are designed for intermittent service at 1000 or less RPM. Examples include driving of small hydraulic pumps, low speed product pumps, and winches.
- 2) Joint Series should be determined using the chart on the following page.

 This symbol warns of possible personal injury.

**General Information**

**Spicer® Universal Joint Engineering Data**

Joint Series	1000	1100	1280	1310
<b>Torque Rating</b>				
Automotive (Gas or Diesel Engine) lb-ft Continuous	50	54	95	130
<b>Tubing</b>				
Diameter	1.750"	1.250"	2.500"	3.000"
Wall Thickness	.065"	.095"	.083"	.083"
W = Welded S = Seamless	W	S	W	W
<b>Flange Diameter</b> (Swing Diameter)				
Rectangular Type	3.500"	3.500"	3.875"	3.875"
<b>Bolt Holes</b> - Flange Yoke				
Circle	2.750"	2.750"	3.125"	3.125"
Diameter	.312"	.312"	.375"	.375"
Number	4	4	4	4
Male Pilot Dia.	2.250"	2.250"	2.375"	2.375"
<b>Distance Across Lugs</b>				
Snap Ring	2.188"	2.656"	3.469"	3.469"
Construction	2.188"	2.656"	3.469"	3.469"
<b>Bearing Diameter</b>	.938"	.938"	1.062"	1.062"

**<sup>1,2</sup> Maximum Operating Speed for Tube or Solid Shaft Diameter and Length**

Tube	RPM - Revolutions per Minute				
	500	1000	1500	2000	2500
OD x Wall Thickness (Joint Type)					
1.750" x .065" (Welded)	117"	82"	67"	58"	52"
1.250" x .095" (Seamless)	91"	64"	52"	45"	40"
2.500" x .083" (Welded)	122"	87"	70"	62"	55"
3.000" x .083" (Seamless)	-	-	-	85"	76"
Solid Shaft	RPM - Revolutions per Minute				
	500	1000	1500	2000	2500
Diameter					
.750"	60"	42"	35"	30"	27"
.812"	62"	44"	36"	31"	28"
.875"	65"	46"	37"	32"	29"
1.000"	69"	49"	40"	35"	31"
1.250"	77"	55"	45"	39"	35"

<sup>1</sup> The numbers expressed above represent the maximum installed length for tubing or solid shaft in both two joint assemblies and joint shaft applications.

<sup>2</sup> Please contact your Chelsea representative for applications with speeds below 500 RPM and over 2500 RPM.

 **WARNING:** Direct customer to driveline manufacturer specifications.

 This symbol warns of possible personal injury.

## General Information

### PTO Shifting Procedure & Precautions

**CAUTION:** This vehicle is equipped with a Power Take-Off. Shut engine off before working on the Power Take-Off or getting below the vehicle. Consult the operating instructions before using the PTO (See sun visor).

POWER TAKE-OFF OPERATION — VEHICLE STATIONARY

#### Automatic Transmission with PowerShift PTO

Engage the PTO with the engine at idle speed.

**NOTE:** PowerShift PTO: The engine must be at idle or below 1000 RPM when the PTO is engaged. See the transmission manufacturer's instructions for special procedures.

#### **IMPORTANT:**

**Failure to follow the proper shifting or operating sequences will result in premature PTO failure with possible damage to other equipment.**



**WARNING:** Cold Weather Operation of PowerShift PTO

During extreme cold weather operation [32°F (0°C) and lower], a disengaged PowerShift Power Take-Off can momentarily transmit high torque that will cause unexpected output shaft rotation. This is caused by the high viscosity of the transmission oil when it is extremely cold. As slippage occurs between the Power Take-Off clutch plates, the oil will rapidly heat up and the viscous drag quickly decreases. The rotation of the PTO's output shaft could cause unexpected movement of the driven equipment, resulting in serious personal injury, death, or equipment damage.

#### **To avoid personal injury or equipment damage:**

- Driven equipment must have separate controls.
- Driven equipment must be left in the disengaged position when not in operation.
- Driven equipment must not be operated until the vehicle is allowed to warm up.

 This symbol warns of possible personal injury.

## General Information

---

### Power Take-Off Maintenance

Due to the normal and sometime severe torsional vibrations that PTOs experience, operators should follow a set maintenance schedule for inspections. Failure to service loose bolts or PTO leaks could result in potential auxiliary Power Take-Off or transmission damage.

Periodic PTO maintenance is required by the owner/operator to ensure proper, safe, and trouble-free operation.

**Daily:** Check all air, hydraulic, and working mechanisms before operating PTO and perform maintenance as required.

**Monthly:** Inspect for possible leaks and tighten all air, hydraulic, and mounting hardware if necessary. Torque all bolts, nuts, etc., to Chelsea's specifications. If applicable, ensure that splines are properly lubricated. Perform maintenance as required.

With regards to the direct mounted pump splines, the PTO requires the application of a specially formulated anti-fretting grease. This grease must be specified for both high pressure and high temperature applications. The addition of the grease has been proven to reduce the effects of torsional vibrations, which result in fretting corrosion on the PTO's internal splines as well as the pump's external splines. Fretting corrosion appears as a rusting and wearing of the pump shaft splines. Severe duty applications, which require long PTO running times and high torque, may require more frequent regreasing. Continuous duty applications with light loads require frequent regreasing due to the higher number of running hours, an example of this is utility trucks. It is important to note that service intervals will vary for every application and they are the responsibility of the end user of the product. Chelsea also recommends that you consult your pump's owner's manual and technical services for their maintenance guidelines. Fretting corrosion is caused by many factors and without proper maintenance; the anti-fretting grease can only reduce its effects on components.

#### Chelsea offers anti-fretting grease to our customers in two package sizes:

- 5/8 fluid ounce tube (PN 379688) - Provided with PTO where applicable
- 14-ounce grease cartridge (PN 379831)

**Warranty:** Failure to comply entirely with the provisions set forth in the appropriate owner's manual will result in voiding of warranty consideration.

**Transmission Overview**

**TorqShift® 5R110 Transmission – Stationary Elevated Idle Control (SEIC)  
 6.7L Diesel and 6.8L Gas**

**Models Affected**

Super Duty – MY2009-MY2016  
 Medium Duty – MY2009-MY2010

**Overview**

**SEIC**

- A Powertrain Control Module (PCM) strategy that provides elevated engine speed to drive auxiliary commercial equipment such as hydraulic pumps, generators, air compressors; or maintain vehicle battery charge under extreme electrical demands.

<b>SEIC Enable/Disable Conditions</b>			
<b>Vehicle Conditions to Enable SEIC (all are required)</b>	<b>Vehicle Conditions that Disable SEIC (any one required)</b>	<b>SEIC</b>	<b>Mobile Mode</b>
Parking brake applied	Parking brake disengaged	Yes	No
Foot off of service brake	Depressing service brake	Yes <sup>(1)</sup>	No <sup>(2)</sup>
Vehicle in PARK (automatic trans.)	Vehicle taken out of PARK	Yes	No
Foot off of accelerator pedal	Accelerator pedal depressed	Yes	No
Vehicle speed is 0 mph (stationary)	Vehicle speed is not 0 mph (stationary)	Yes	No
Brake lights functional	Brake light circuit disconnected	Yes	Yes
Engine at a stable base idle speed		Yes	No
Transmission oil Temp above 20°F	Transmission Oil Temperature (TOT) Limit exceeds 240°F on Diesel and 250°F on Gas	Yes	Yes
Eng Coolant Temp above 20°F <sup>(3)</sup>	Engine Coolant Temperature (ECT) above 234°F	No	Yes
Eng Coolant Temp above 140°F	Engine Coolant Temperature (ECT) above 220°F	Yes <sup>(1)</sup>	No
	Catalyst Temperature Limit	Yes	Yes

<sup>(1)</sup> A "Change-of-State" at the "PTO-Request" circuit is required to re-invoke SEIC. When a disabler is seen by the PCM, the "PTO-Indicator" circuit changes from "Ground-Source" to an "Open Circuit". After approximately 3 seconds SEIC drops out, returning the engine speed to base idle. For vehicle-stationary operation, the automatic transmission torque converter unlocks as engine speed proceeds below 1200 RPM. To re-initiate SEIC the operator must turn off the aftermarket PTO switch (removing command voltage to the "PTO-Mode" circuit) and then turn it back on again.

<sup>(2)</sup> SEIC is automatically reactivated after approximately 3 seconds after the disabling condition is removed.

<sup>(3)</sup> MY2013 Gas Engine Applications Engine Coolant Temperature above 30°F.

Reference Ford Body Builder website for year specific information at <https://www.fleet.ford.com/truckbbas/>

## Transmission Overview

### TorqShift® 5R110 Transmission – Stationary Elevated Idle Control (SEIC) (Cont'd) 6.7L Diesel and 6.8L Gas

#### Models Affected

Super Duty – MY2009-MY2016  
Medium Duty – MY2009-MY2010

#### General System Behavior

- To guarantee full advertised torque capability at the automatic transmission PTO gear and through the aftermarket PTO clutch, the transmission torque converter must be locked, and the hydraulic line pressure serving the aftermarket PTO clutch must be elevated. Applying battery voltage to the PTO circuit is the signal to the transmission to enter SEIC strategy and command these two important functions. This applies to both stationary and mobile PTO operations.
- If an SEIC disabler occurs:
  - GAS engines will require a "change-of-state", meaning the operator is required to turn off voltage to the "PTO-Request" circuit, and back on again to re-invoke SEIC and PTO operation.
  - DIESEL engines do not require a "change-of-state" at the "PTO" circuit. Once the disabling condition is removed, the strategy re-invokes SEIC after approximately 3 seconds, automatically returning the engine speed back to what was commanded by the operator prior to the disabling condition.
- Battery Charge Protection (BCP): A diesel-only function. When it is switched on the engine speed goes immediately to 1200 RPM and stays there even if the battery is fully charged. From this state it uses system voltage, as well as ambient air temperature, and engine oil temperature information to raise engine speed higher to maintain a certain battery charge. Maximum engine speed in BCP mode is 2400 RPM. The BCPSW circuit may be wired to circuit to Ignition-Hot-in-Run to make it "automatic" for ambulance. Park-Brake-Set is one of the enablers of BCP.
- The Transmission Control Module (TCM) will turn off the PTO system when Transmission Oil Temperature (TOT) reaches 240°F on Diesel and 250°F on Gas.
- SEIC/PTO strategy function in the PCM is not affected by the loss of vehicle battery electrical power.
- SEIC Ramp Rate (fixed, not programmable):
  - GAS engines: 400 RPM/second.
  - DIESEL engines: When first applying battery voltage to the PTO circuit the PCM directs the engine to go to the initial target that it sees at the RPM circuit at 200 RPM/second (1200 RPM if there is no resistor in the RPM circuit – open circuit). If resistance is subsequently changed at the RPM circuit then the ramp rate to this second speed target is virtually instantaneous (as fast as the diesel engine can get there).
- Correlation between engine speed and resistor values:
  - The external voltage source that the aftermarket PTO system designer uses to command SEIC through the "PTO" or "PTO-Request" circuits must be the same as that used by the PCM internally for predictable SEIC function. Reasoning is that a fully charged vehicle battery fluctuates with ambient temperature.
  - The correlation will be better for diesel engines since the diesel engine SEIC system offers buffered PCM voltage and ground circuits to complete the resistor circuits for engine speed, while the gas engine system forces the SEIC circuit installer to use chassis voltage and ground.

Reference Ford Body Builder website for year specific information at <https://www.fleet.ford.com/truckbbas/>

## Transmission Overview

### TorqShift® 5R110 Transmission – Stationary Elevated Idle Control (SEIC) (Cont'd) 6.7L Diesel and 6.8L Gas

#### Models Affected

Super Duty – MY2009-MY2016  
Medium Duty – MY2009-MY2010

#### General System Behavior (Cont'd)

- Correlation between engine speed and resistor values (Cont'd):
  - If there is a high electrical demand on the chassis battery, such as from aftermarket inverters or generators, etc., the actual elevated idle engine speed may vary with that demand for any given resistance in the SEIC circuit. More so for gas engine systems than diesel since gas engine uses chassis battery voltage as a reference.
- GAS Engine Only:
  - Normal base engine calibration allows approximately +/-50 RPM fluctuation. If any factory vehicle accessories are used during SEIC, e.g. A/C, defroster, etc., then that fluctuation may increase to approximately +/-100 RPM or more.
  - The sudden loss of aftermarket PTO hydraulic pressure during SEIC/PTO operation, like a ruptured hose, may send SEIC engine speed to near 3000 RPM. It is recommended that a hydraulic pressure switch linked to SEIC/PTO be added to disable SEIC/PTO when a hose ruptures.
  - Because of a service brake circuit characteristic at engine-start, invoking SEIC may cause the diagnostic error code FFG\_BOO to get flagged (recorded in the PCM). To avoid this, simply tap the service brake pedal sometime after engine-start and prior to invoking SEIC. Once the code is set, SEIC may not be available until it is erased.
  - Gas engines require a "change-of-state" at the PTO-Mode and PTO-Engage circuits whenever a disabler turns off SEIC (remove battery voltage signal and re-apply).
  - For aftermarket remote engine start-stop: a change-of-state is required to get SEIC to function again.

#### Special Situations

##### Mobile PTO Operation (TorqShift® Automatic or M6 manual Transmission)

Always apply battery voltage to the PTO wire to keep SEIC active. Engine speed is no longer commanded by SEIC, instead it is controlled by the foot throttle. The increased line pressure and torque converter commands must remain active to protect the automatic transmission. Convert PTO solenoid power to direct-battery instead of through the SEIC circuit suggested in this bulletin, possibly using the VSO signal circuit. A slightly harsher automatic transmission shift can be expected but is harmless.

##### Alternative Calibration

All new Ford light trucks have an "Alternative Calibration" or ALT-CAL installed in the PCM that conditions the powertrain during its early lifetime. It may increase the PARK-idle or drive-idle speed of the engine, by as small as 50 RPM or by several hundred. It affects SEIC initiation by not letting it activate, because one of the SEIC enablers is having a steady, base, idle speed, generally near 650 RPM. If ALT-CAL sets the idle at 700 RPM then SEIC activation will be prevented. ALT-CAL is normally removed after 50 key-on starts, or by driving over 5 continuous miles; it is also sometimes erased by disconnecting the battery for a minute or so.

Reference Ford Body Builder website for year specific information at <https://www.fleet.ford.com/truckbbas/>

**Transmission Overview**

**TorqShift® 6R140 Transmission – Stationary Elevated Idle Control (SEIC)  
 6.7L Diesel**

**Models Affected**

Super Duty – MY2011-MY2019  
 Medium Duty – MY2016-MY2019

**Overview**

**SEIC**

- A Powertrain Control Module (PCM) strategy that provides elevated engine speed to drive auxiliary commercial equipment such as hydraulic pumps, generators, air compressors; or maintain vehicle battery charge under extreme electrical demands.

<b>SEIC Enable/Disable Conditions</b>			
<b>Vehicle Conditions to Enable SEIC (all are required)</b>	<b>Vehicle Conditions that Disable SEIC (any one required)</b>	<b>SEIC</b>	<b>Mobile Mode</b>
Parking brake applied	Parking brake disengaged	Yes	No
Foot off of service brake	Depressing service brake	Yes <sup>(1)</sup>	No <sup>(2)</sup>
Vehicle in PARK (automatic trans.)	Vehicle taken out of PARK	Yes	No
Foot off of accelerator pedal	Accelerator pedal depressed	Yes	No
Vehicle speed is 0 mph (stationary)	Vehicle speed is not 0 mph (stationary)	Yes	No
Brake lights functional (Select model years)	Brake light circuit disconnected	Yes	Yes
Engine at a stable base idle speed		Yes	No
Transmission Oil Temp above 20°F	Transmission Oil Temperature (TOT) Limit exceeds 240°F on Diesel and 250°F on Gas	Yes <sup>(1)</sup>	Yes
Eng Coolant Temp above 20°F <sup>(3)</sup>	Engine Coolant Temperature (ECT) Limit	No	Yes
Eng Coolant Temp above 40°F (Select model years)	Engine Coolant Temperature (ECT) Limit	Yes <sup>(1)</sup>	No
	Catalyst Temperature Limit	Yes <sup>(1)</sup>	Yes

<sup>(1)</sup> A "Change-of-State" at the "PTO-Request" circuit is required to re-invoke SEIC. When a disabler is seen by the PCM, the "PTO-Indicator" circuit changes from "Ground-Source" to an "Open Circuit". After approximately 3 seconds SEIC drops out, returning the engine speed to base idle. For vehicle-stationary operation, the automatic transmission torque converter unlocks as engine speed proceeds below 1200 RPM. To re-initiate SEIC the operator must turn off the aftermarket PTO switch (removing command voltage to the "PTO-Mode" circuit) and then turn it back on again.

<sup>(2)</sup> SEIC is automatically reactivated after approximately 3 seconds after the disabling condition is removed.

<sup>(3)</sup> MY2013 Gas Engine Applications Engine Coolant Temperature above 140°F.

Reference Ford Body Builder website for year specific information at <https://www.fleet.ford.com/truckbbas/>

## Transmission Overview

### TorqShift® 6R140 Transmission – Stationary Elevated Idle Control (SEIC) (Cont'd) 6.7L Diesel

#### Models Affected

Super Duty – MY2011-MY2019  
Medium Duty – MY2016-MY2019

#### General System Behavior

- To guarantee full advertised torque capability at the automatic transmission PTO gear and through the aftermarket PTO clutch, the hydraulic line pressure serving the aftermarket PTO clutch must be elevated. Applying battery voltage to the PTO circuit is the signal to the transmission to enter SEIC strategy and this important functions. This applies to both stationary and mobile PTO operations.
- If an SEIC disabler occurs:
  - ALL engines will require a "change-of-state", meaning the operator is required to turn off voltage to the "PTO-Request" circuit, and back on again to re-invoke SEIC and PTO operation.
- Battery Charge Protection (BCP):
  - When it is switched on the engine speed goes immediately to 600 RPM and stays there even if the battery is fully charged. From this state it uses system voltage, as well as ambient air temperature, and engine oil temperature information to raise engine speed higher to maintain a certain battery charge. Maximum engine speed in BCP mode is 1200 RPM.
- Auto Entry:
  - The BCP and Live-Drive operation modes allow PTO to engage automatically once the engine started provided the input switch is left in the on position prior to starting the engine. However, loss of an operating condition after PTO is initially engaged will require the switch to be cycled before PTO will re-engage.
- The Transmission Control Module (TCM) will turn off the PTO system when Transmission Oil Temperature (TOT) reaches 240°F on Diesel and 250°F on Gas.
- SEIC/PTO strategy function in the PCM is not affected by the loss of vehicle battery electrical power.
- SEIC Ramp Rate (fixed, not programmable):
  - When first applying battery voltage to the PTO circuit the PCM directs the engine to go to the initial target that it sees at the RPM circuit at 200 RPM/second.
  - The correlation will be better for diesel engines since the diesel engine SEIC system offers buffered PCM voltage and ground circuits to complete the resistor circuits for engine speed.
  - If there is a high electrical demand on the chassis battery, such as from aftermarket inverters or generators, etc., the actual elevated idle engine speed may vary with that demand for any given resistance in the SEIC circuit.

Reference Ford Body Builder website for year specific information at <https://www.fleet.ford.com/truckbbas/>

## Transmission Overview

### TorqShift® 6R140 Transmission – Stationary Elevated Idle Control (SEIC) (Cont'd) 6.7L Diesel

#### Models Affected

Super Duty – MY2011-MY2019  
Medium Duty – MY2016-MY2019

#### General System Behavior (Cont'd)

#### Special Situations

Stationary mode, Live Drive, and Split Shaft operation are supported.

#### Stationary Mode

Operates in Park at elevated engine speed. The maximum load at the transmission PTO gear is 250 lb-ft [338.95 N-m].

#### Mobile Mode

Operates in all gears and all vehicle speeds. The engine idle speed is slightly elevated, but peak engine speed is not limited beyond normal operating ranges. An additional rev limiter may be required to prevent over speed damage to attached pumps and equipment. The maximum load allowable for mobile mode is 150 lb-ft [203.37 N-m] at the transmission PTO gear. If the PTO feature is used for extended periods of time without vehicle movement it is recommended to switch to Stationary Mode.

#### Split Shaft Mode

**NOTE:** Split Shaft mode engagement procedure has changed for MY2013.

To install Split Shaft mode, wire according to the diagram shown on [page 9](#) of Ford SVE Bulletin Q-180R4. Select elevated idle speed by installing a resistor (which provides voltage to PTO RPM input) as indicated in the wiring diagram. Split Shaft mode requires that supply voltage (nominal 12VDC) be applied to both the PTORS1 and PTORS2 circuits.

#### Adaptive Cooling

This PCM strategy is new for 2011 6.7L diesel engine. It automatically restricts engine power when it senses an over-temperature condition and may interrupt the SEIC-PTO operation. Typically, the over-temperature condition it reacts to will also show up on the temperature gage on the instrument panel. Elevated engine speed, typical of SEIC operation, may help avoid Adaptive Cooling occurrence due to the resultant additional engine and transmission coolant flow. However, depending on the auxiliary PTO power being demanded, 900 RPM may not be enough to prevent the power train from entering Adaptive Cooling mode, but 1500 RPM may.

Reference Ford Body Builder website for year specific information at <https://www.fleet.ford.com/truckbbas/>

**Transmission Overview**

**TorqShift® 6R140 Transmission – Stationary Elevated Idle Control (SEIC)  
 6.8L Gas**

**Models Affected**

Super Duty – MY2017-MY2019  
 Medium Duty – MY2013-MY2019

**General System Behavior**

Purpose to explain changes and functions of the (SEIC) system for Power Take-Off (PTO) applications.

**Overview – SEIC and Transmission PTO (6.8L only)**

- A powertrain control module (PCM) strategy that provides elevated engine speed to drive auxiliary commercial equipment such as hydraulic pumps, generators, air compressors; or maintain vehicle battery charge under extreme electrical demands.
- SEIC is standard in all PCMs for F-650 with the 6.8L gas engine.

<b>SEIC Enable/Disable Conditions</b>		
<b>Vehicle Conditions to Enable SEIC (all are required)</b>	<b>Vehicle Conditions that Disable SEIC (any one required)</b>	<b>SEIC</b>
Parking brake applied	Parking brake disengaged	Yes
Foot off of service brake	Depressing service brake	Yes <sup>(1)</sup>
Vehicle in PARK (automatic trans.)	Vehicle taken out of PARK	Yes
Foot off of accelerator pedal	Accelerator pedal depressed	Yes
Vehicle speed is 0 mph (stationary)	Vehicle speed is not 0 mph (stationary)	Yes
Brake lights functional (Select model years)	Brake light circuit disconnected	Yes
Engine at a stable base idle speed		Yes
Transmission Oil Temp above 20°F	Transmission Oil Temperature (TOT) Limit exceeds 240°F on Diesel and 250°F on Gas	Yes <sup>(1)</sup>
Eng Coolant Temp above 20°F <sup>(3)</sup>	Engine Coolant Temperature (ECT) Limit	No
Eng Coolant Temp above 40°F (Select model years)	Engine Coolant Temperature (ECT) Limit	Yes <sup>(1)</sup>
	Catalyst Temperature Limit	Yes <sup>(1)</sup>

<sup>(1)</sup> A "Change-of-State" at the "PTO-Request" circuit is required to re-invoke SEIC. When a disabler is seen by the PCM, the "PTO-Indicator" circuit changes from "Ground-Source" to an "Open Circuit". After approximately 3 seconds SEIC drops out, returning the engine speed to base idle. For vehicle-stationary operation, the automatic transmission torque converter unlocks as engine speed proceeds below 1200 RPM. To re-initiate SEIC the operator must turn off the aftermarket PTO switch (removing command voltage to the "PTO-Mode" circuit) and then turn it back on again.

<sup>(2)</sup> SEIC is automatically reactivated after approximately 3 seconds after the disabling condition is removed.

<sup>(3)</sup> MY2013 Gas Engine Applications Engine Coolant Temperature above 140°F.

Reference Ford Body Builder website for year specific information at <https://www.fleet.ford.com/truckbbas/>

## Transmission Overview

### TorqShift® 6R140 Transmission – Stationary Elevated Idle Control (SEIC) (Cont'd) 6.8L Gas

#### Models Affected

Super Duty – MY2017-MY2019

Medium Duty – MY2013-MY2019

#### General System Behavior (Cont'd)

##### Customer Access Wires for SEIC and VSO/CTO/PARK Signals

- Located under hood, below left (passenger) side engine cowl.
- The final stage manufacturer or up-fitter is required to supply the customer interface equipment.

##### Transmission PTO Gear and Port

- Available on 6.8L F-650.
- Available for TorqShift® 6-speed automatic transmission.
- The PTO gear is direct splined to the torque converter cover and thus able to deliver power any time the engine is running (i.e. no internal PTO clutch).
- NEVER use any sealer, especially silicone-based, on the PTO port gasket.
- The PTO gear delivers up to 250 lb-ft [338.95 N-m] torque to the aftermarket PTO and can manage the heat of 40 HP continuously. Higher horsepower can be delivered, but for shorter durations depending on the amount of power required.

#### Product Descriptions/Special Situations

##### SEIC

- Intended to be commanded ONLY by applying battery voltage to certain customer-access blunt-cut wire circuits, and adding a target-speed resistor, and is only available when the vehicle road speed signal is zero.
- Includes a link circuit which changes from open circuit to ground when enablers are met, that may be used to turn on an indicator lamp, while providing battery power to an aftermarket PTO clutch or solenoid.
- Ramp rates are fixed and cannot be altered by the customer.
- Maximum engine speed is 2400 RPM without PTO installed.

**NOTE:** Chelsea PTO output speed should not exceed 2500 RPM. The PTO is 124% of engine speed. **DO NOT** exceed 2,016 engine RPMs with Chelsea PTO installed.

- Minimum engine speed – Gas engine: 910 RPM approximately. Gas engine has a 900 RPM “stand-by” speed that it first goes to when SEIC is initiated to step it away from stall speed that it could dip to as PTO load is applied. This is an unusable speed for any application. However, a resistor can be chosen that sets the useable target speed for carrying an auxiliary load to just above 900 RPM This is mainly intended for applications using a FEAD-driven PTO device like a clutch-pump, because the TorqShift® torque converter cannot fully lock until 900 RPM engine speed RPM.



**WARNING:** Using the TorqShift® PTO below 900 RPM for the 6.8L risks transmission damage from over-heating, or aftermarket PTO clutch slippage debris.



This symbol warns of possible personal injury.

Reference Ford Body Builder website for year specific information at <https://www.fleet.ford.com/truckbbas/>

## Transmission Overview

### TorqShift® 6R140 Transmission – Stationary Elevated Idle Control (SEIC) (Cont'd) 6.8L Gas

#### Models Affected

Super Duty – MY2017-MY2019

Medium Duty – MY2013-MY2019

#### General System Behavior (Cont'd)

To guarantee full advertised torque capability at the automatic transmission PTO gear and through the aftermarket PTO clutch, the transmission torque converter must be locked, and the hydraulic line pressure serving the aftermarket PTO clutch must be elevated. Applying battery voltage to the PTO circuit is the signal to the transmission to enter SEIC strategy and command these two important functions.

- If an SEIC enabling condition is not met upon SEIC initialization:
  - SEIC will not initialize. SEIC will require a "change-of-state" (voltage to both the "PTO\_REQUEST" and "PTO\_ENGAGE" circuits removed completely). The enabling conditions must be met, and then SEIC and PTO operation may be initiated.
- If an SEIC disabler occurs:
  - GAS engines will require a "change-of-state", meaning the operator is required to turn off voltage to both the "PTO\_REQUEST" and "PTO\_ENGAGE" circuits, and back on again to re-invoke SEIC and PTO operation.
  - The Transmission Control Module (TCM) will turn off the PTO system when Transmission Oil Temperature (TOT) reaches 240°F on Diesel and 250°F on Gas.
  - SEIC/PTO strategy function in the PCM is not affected by the loss of vehicle battery electrical power.
- SEIC Ramp Rate Max (Not programmable and approximate):
  - 400 RPM/second up and 200 RPM/second down.
- Correlation between engine speed and resistor values:
  - The external voltage source that the aftermarket PTO system designer uses to command SEIC through the "PTO\_REQUEST" or "PTO\_ENGAGE" circuits must be the same as that used by the PCM internally for predictable SEIC function. Reasoning is that a fully charged vehicle battery fluctuates with ambient temperature.
  - If there is a high electrical demand on the chassis battery, such as from aftermarket inverters or generators, etc., the actual elevated idle engine speed may vary with that demand for any given resistance in the SEIC circuit. This has a greater effect on gas engine systems than it does on diesel since gas engine uses chassis battery voltage as a reference.

#### Product Descriptions/Special Situations

##### SEIC (Cont'd)

- Normal base engine calibration allows approximately +/-50 RPM fluctuation. If any factory vehicle accessories are used during SEIC, e.g. A/C, defroster, etc., then that fluctuation may increase to approximately +/-100 RPM or more.
- The sudden loss of aftermarket PTO hydraulic pressure during SEIC/PTO operation, like a ruptured hose, may send SEIC engine speed to near 3000 RPM. It is recommended that a hydraulic pressure switch linked to SEIC/PTO be added to disable SEIC/PTO when a hose ruptures.
- Because of a service brake circuit characteristic at engine-start, invoking SEIC may cause the diagnostic error code FFG\_BOO to get flagged (recorded in the PCM). To avoid this, simply tap the service brake pedal sometime after engine-start and prior to invoking SEIC. Once the code is set, SEIC may not be available until it is erased.
- Gas engines require a "change-of-state" at the PTO\_REQUEST and PTO\_ENGAGE circuits whenever a disabler turns off SEIC (remove battery voltage signal and re-apply).

Reference Ford Body Builder website for year specific information at <https://www.fleet.ford.com/truckbbas/>

## Transmission Overview

### TorqShift® 6R140 Transmission – Stationary Elevated Idle Control (SEIC) 6.7L Diesel (MY2020-MY2025)/7.3L Gas

#### Models Affected

Medium Duty – MY2020-MY2025

#### Stationary Elevated Idle Control (SEIC)

- A power train control module (PCM) strategy that provides elevated engine speed to drive auxiliary commercial equipment such as hydraulic pumps, generators, air compressors; or maintain vehicle battery charge under extreme electrical demands.
- SEIC is standard in all PCM's for F-650/F-750 trucks.
- 6.7L diesel only - Split shaft mode engages the transmission output shaft.

#### Customer Access Circuit/SEIC Wire Locations

SEIC circuits, Customer Access Signal Circuits.

#### Customer Access Wires for SEIC and VSO/CTO/PARK Signals

- The final stage manufacturer or up-fitter is required to supply the customer interface equipment.
- Additional information in the "Circuit Descriptions" section.
- SEIC Circuits are now located underhood on the Driver's Side as shown in the picture below:

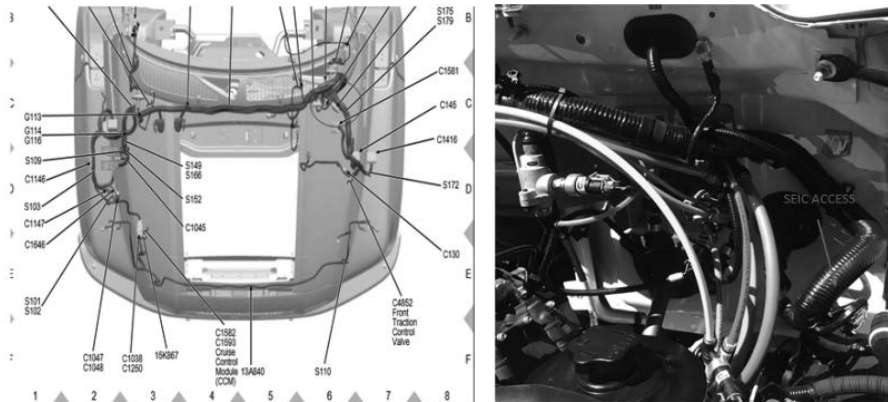

#### Transmission Power Take-Off (PTO) Gear and Port

- Available on F-650/F-750.
- Available for TorqShift® 6-speed automatic transmission by ordering "Transmission Power Take-Off Provision". The PTO gear is direct splined to the torque converter impeller.
- NEVER use any sealer, especially silicone-based, on the PTO port gasket.
- TorqShift® Automatic Transmission: On the 6.7 diesel engine, the PTO gear delivers up to 300 lb-ft [406.74 N-m] of torque to the aftermarket PTO and 250 lb-ft [338.95 N-m] of on the 7.3L gasoline engine. The powertrain cooling system can manage the heat of 60 HP on the 6.7L diesel engine and 40 HP on the 7.3L gasoline engine during continuous operation. Higher horsepower can be delivered, but for shorter durations depending on the amount of power required.
- Some aftermarket PTOs may not be capable of using the full available torque. Consult with the aftermarket PTO supplier to ensure the appropriate PTO selected for the application.

Reference Ford Body Builder website for year specific information at <https://www.fleet.ford.com/truckbbas/>

**Transmission Overview**

**TorqShift® 6R140 Transmission – Stationary Elevated Idle Control (SEIC) (Cont'd)  
 6.7L Diesel (MY2020-MY2025)/7.3L Gas**

**Models Affected**

Medium Duty – MY2020-MY2025

PTO Mode Specifications				
Engine	Mode	Max. Load at Transmission PTO Gear	Minimum Engine RPM	Maximum Engine RPM
6.7L Diesel	Stationary	300 lb-ft [406.74 N-m]	900	3000
	Mobile	200 lb-ft [271.16 N-m]	750	3000
	Split - Shaft	N/A	700	3000
7.3L Gasoline	Stationary	250 lb-ft [338.95 N-m]	800	2400
	Mobile	125 lb-ft [169.48 N-m]	750	6500

**Operating Modes**

**Stationary Elevated Idle Control mode**

- Operates in Park at elevated engine speed. The maximum load at the transmission PTO gear are shown in the table below:

Engine	Max. Load at Transmission PTO Gear, Stationary
6.7L Diesel	300 lb-ft [406.74 N-m]
7.3L Gasoline	250 lb-ft [338.95 N-m]

- Intended to be commanded ONLY by applying battery voltage to certain customer-access blunt-cut wire circuits, and adding a target-speed resistor, and is only available when the vehicle road speed signal is zero.
- Includes a circuit which changes from open circuit to ground when enablers are met that may be used to turn on an indicator lamp while providing battery power to an aftermarket PTO clutch or solenoid.

**Engine speed ramp-rates are configurable, by means of an IDS tool, for all powertrains**

- Default ramp-rate for all powertrains is 200 RPM/second.
- Configurable ramp rates are as follows:
  - Diesel: 100-800 RPM/second (in 100 RPM/second increments)
  - Gas: 100-1000 RPM/second (in 100 RPM/second increments)

**Typical SEIC Engagement Sequence for TorqShift® PTO**

1. 12VDC is applied to PTQ REQ1 circuit.
2. PCM looks for the following enabling conditions:
  - Parking brake applied
  - Foot off of service brake
  - Vehicle in PARK (or NEUTRAL)
  - Foot off of accelerator pedal
  - Vehicle speed is 0 mph (stationary)
  - Engine at a stable base idle speed
  - Transmission Oil Temp above 20°F
  - 6.7L only - Engine Coolant Temperature (ECT) 20°F minimum
  - 7.3L only - Engine Coolant Temperature (ECT) 20°F minimum

Reference Ford Body Builder website for year specific information at <https://www.fleet.ford.com/truckbbas/>

**Transmission Overview**

**TorqShift® 6R140 Transmission – Stationary Elevated Idle Control (SEIC) (Cont'd)  
 6.7L Diesel (MY2020-MY2025)/7.3L Gas**

**Models Affected**

Medium Duty – MY2020-MY2025

**Typical SEIC Engagement Sequence for TorqShift® PTO (Cont'd)**

3. Command is sent to boost the transmission hydraulic line pressure to a minimum of 150 PSI, which is used by the aftermarket PTO supplier to hold their PTO Clutch. Command is sent to increase engine speed to 900 RPM.
4. The PTO RLY circuit changes from open circuit to ground. If the up-fitter uses the circuit wiring offered in this bulletin then this will provide battery voltage to the aftermarket PTO solenoid to engage the PTO.
5. Engine RPM ramps to target speed determined by the resistor selection.

**Mobile Mode**

- Operates in all gears and all vehicle speeds. The engine idle speed is elevated to 750 RPM when the Mobile Mode is initiated.

Engine RPM is controlled by the driver through the throttle pedal and is limited to upfitter selected peak engine speed.

- RPM limiting (2018 model year and later 6.7L diesel vehicles only).
- RPM limiting controls engine speed in Mobile Mode below a selectable maximum threshold. Maximum RPM is determined by the resistor installed between the PTO\_REF and PTO RPM circuits.

See table for RPM/resistor values.

- Transmission behavior changes in Mobile Mode due to upshifting performance; e.g., it is possible for a customer to reach maximum RPM in a lower gear, and the transmission is unable to accelerate – or upshift – to the next gear.
- If this action is not desired, the operator can
  1. Ease up on the accelerator pedal and receive an upshift, or
  2. Put the transmission in manual mode and select the gears manually.
- Selected target RPM has a margin of +/- 15% based on transient conditions (for example, descending a grade).
- Mobile PTO may overshoot the selected RPM by 100-200 RPM for drivability.

The Maximum load allowable for mobile mode are shown in the table below.

- If the PTO feature is used for extended periods of time without vehicle movement it is recommended to switch to Stationary Mode.

Engine	Max. Load at Transmission PTO Gear, Mobile Mode
6.7L Diesel	200 lb-ft [271.16 N-m]
7.3L Gasoline	125 lb-ft [169.48 N-m]

Reference Ford Body Builder website for year specific information at <https://www.fleet.ford.com/truckbbas/>

## Transmission Overview

### TorqShift® 6R140 Transmission – Stationary Elevated Idle Control (SEIC) (Cont'd) 6.7L Diesel (MY2020-MY2025)/7.3L Gas

#### Models Affected

Medium Duty – MY2020-MY2025

#### Typical Mobile Mode Engagement Sequence

1. 12VDC applied to PTO REQ2 circuit.
2. PCM looks for the following enabling conditions:
  - Transmission Oil Temperature above 20°F
  - 6.7L only - Engine Coolant Temperature (ECT) 20°F minimum
  - 7.3L only - Engine Coolant Temperature (ECT) 20°F minimum
3. PCM looks for voltage on PTO RPM circuit.
4. Command is sent to boost transmission hydraulic line pressure to a minimum of 150 PSI, which is used by the aftermarket PTO supplier to hold their PTO Clutch.
5. The PTO RLY circuit changes from open circuit to ground. If the up-fitter uses the circuit wiring offered in this bulletin then this will provide battery voltage to the aftermarket PTO solenoid to engage the PTO.
6. Engine idle increases to 750 RPM.

#### Split Shaft Mode (Diesel Only)

- To install Split Shaft mode, wire according to the diagram. Select elevated idle speed by installing a resistor (which provides voltage to PTO RPM input) as indicated in the wiring diagram. Split Shaft mode requires that supply voltage (nominal 12VDC) be applied to both the PTO REQ1 and PTO REQ2 circuits.

#### Split Shaft Engagement procedure:

1. Ensure the following engine is running and the engine coolant temperature is above 20°F.
2. Apply park brake.
3. Disconnect vehicle drive train (transmission in NEUTRAL, 4x4 DISENGAGED) and engage PTO load.
4. With foot off both the service brake and accelerator pedals, turn Split Shaft PTO on, and engine speed will lift to approximately 650 RPM stand-by speed.
5. While pressing the service brake, shift transmission into drive, brake pedal must remain depressed for a minimum of 3 seconds after moving gear shift lever into drive position in order to enable Split Shaft Mode.
6. The system will raise transmission hydraulic line pressure, shift into 4th gear, and lock the converter (keep service brake depressed minimum of three seconds after transition into drive). Release service brake and engine speed will ramp up to target idle speed in a controlled manner.

If vehicle unexpectedly lurches or moves upon releasing service brake, immediately depress brake pedal, and shift transmission into PARK or NEUTRAL to secure vehicle. Contact Upfitter immediately.

Reference Ford Body Builder website for year specific information at <https://www.fleet.ford.com/truckbbas/>

## Transmission Overview

### TorqShift® 6R140 Transmission – Stationary Elevated Idle Control (SEIC) (Cont'd) 6.7L Diesel (MY2020-MY2025)/7.3L Gas

#### Models Affected

Medium Duty – MY2020-MY2025

#### Battery Charge Protect (BCP):

- When 12VDC is applied to the BCP SW circuit, the engine speed goes immediately to 600. From this state, the PCM uses battery voltage, as well as ambient air temperature, and engine oil temperature information to raise engine speed higher to maintain battery charge. Maximum engine speed in BCP mode is 1200 RPM. Loss of an operating condition after BCP is engaged will require the BCP switch to be cycled before BCP will re-engage.
- BCP CANNOT BE ACTIVE WHEN SEIC OR PTO MODES ARE ACTIVE.
- A Resistor must be installed between PTO REF and PTO RPM for both Diesel and Gasoline engines.

#### Typical Battery Charge Protect Mode

##### Engagement Sequence:

1. 12VDC applied to BCP SW circuit.
2. PCM looks for the following enabling conditions:
  - Parking brake applied
  - Foot off of service brake
  - Vehicle in PARK (or NEUTRAL)
  - Foot off of accelerator pedal
  - Vehicle speed is 0 mph (stationary)
  - Engine at a stable base idle speed
  - Transmission Oil Temp above 20°F
  - 6.7L only - Engine Coolant Temperature (ECT) 20°F minimum
  - 7.3L only - Engine Coolant Temperature (ECT) 20°F minimum
3. PCM looks for a valid voltage between 0.2 to 4.7 Volts on the PTO RPM circuit.
4. Vehicle idle fluctuates slightly as PCM enters BCP mode.
5. The BCP LP circuit changes from open circuit to ground. This is intended to provide a ground path for a BCP indicator lamp.

**NOTE:** BCP is a smart system. Engine idle will not increase unless the vehicle senses an increase in electrical demand. Under periods of low electrical demand, the operator may not notice any change in engine RPM. It is recommended that the modifier install an indicator lamp to alert the operator that BCP is properly engaged.

#### Additional notes:

##### Adaptive Cooling

This PCM strategy automatically restricts engine power when it senses an over-temperature condition and may interrupt the SEIC-PTO operation. Typically, the over-temperature condition it reacts to will also show up on the temperature gage on the instrument panel. Elevated engine speed, typical of SEIC operation, may help avoid Adaptive Cooling occurrence due to the resultant additional engine and transmission coolant flow. However, depending on the auxiliary PTO power being demanded, 900 RPM may not be enough to prevent the power train from entering Adaptive Colling mode, but 1500 RPM may.

##### Input Resistor

ALL modes (SEIC, PTO) require usage of an input resistor. The resistor value can be determined using the information provided in the appendix of this owner's manual ([pages 82-84](#)). It is important to verify your required resistor value by using Ford's Body Builder website.

Reference Ford Body Builder website for year specific information at <https://www.fleet.ford.com/truckbbas/>

Transmission Overview

**TorqShift® 6R140 Transmission – Stationary Elevated Idle Control (SEIC) (Cont'd)  
6.7L Diesel (MY2020-MY2025)/7.3L Gas**

**Models Affected**

Medium Duty – MY2020-MY2025

Vehicle Conditions to Enable SEIC (all are required)	Vehicle Conditions that Disable SEIC (any one required - See Note-1)	SEIC	Split Shaft (Diesel only)	Mobile Mode	BCP
Parking brake applied	Parking brake disengaged	Yes	Yes	No	Yes
Foot off of service brake	Depressing service brake	Yes	See note - 4	No	Yes
Vehicle in PARK (or NEUTRAL)	Vehicle take out of PARK (or NEUTRAL)	Yes	See note - 4	No	Yes
Foot off of accelerator pedal	Accelerator pedal depressed	Yes	Yes	No	Yes
Vehicle speed is 0 mph (stationary)	Vehicle speed is not 0 mph (stationary)	Yes	Yes	No	Yes
Engine at a stable base idle speed		Yes	Yes	No	Yes
Transmission Oil Temp above 20°F	Transmission Oil Temperature (TOT) exceeds 240°F	Yes	Yes	Yes	Yes
Engine Coolant Temperature (ECT) 20°F minimum (6.7L)	Engine Coolant Temperature (ECT) exceeds 230°F	Yes	Yes	Yes	No
Engine Coolant Temperature (ECT) 20°F minimum (7.3L)	Engine Coolant Temperature Limit (ECT) 230°F maximum	Yes	N/A	Yes	Yes
	Catalyst Temperature Limit	Yes	Yes	Yes	Yes

**NOTE 1:** A “change-of-state” at the **PTO REQ1** input (for Stationary Elevated Idle Control non-Split Shaft), or for both **PTO REQ1** and **PTO REQ2** inputs (for Stationary Elevated Idle Control Split Shaft) is required to re-invoke Stationary Elevated Idle Control. When a disable is seen by the PCM, the Stationary Elevated Idle Control function is deactivated, the **PTO RLY** output circuit changes from a “ground-source” to “open circuit”, and engine speed returns to base idle. To re-activate Stationary Elevated Idle Control, the operator must open the PTO Switch to the **PTO REQ1** and **PTO REQ2** inputs, then close the PTO Switch again to the **PTO REQ1** or **PTO REQ1** and **PTO REQ2** inputs.

**NOTE 2:** A “change-of-state” at the **PTO REQ2** input is required to re-invoke Mobile PTO. When a disable is seen by the PCM, the Mobile PTO function is deactivated, the **PTO RLY** output circuit changes from a “ground-source” to “open circuit”, and engine speed returns to base idle. To re-activate Mobile PTO, the operator must open the PTO Switch to the **PTO REQ2** input, then close the PTO Switch again to the **PTO REQ2** input.

**NOTE 3:** A “change-of-state” at the **BCP SW** input is required to re-invoke Battery Charge Protect. When a disable is seen by the PCM, the Battery Charge Protect function is deactivated, the **BCP LP** output circuit changes from a “ground-source” to “open circuit”, and engine speed returns to base idle. To re-activate Battery Charge Protect, the operator must open the Battery Charge Protect Switch to the **BCP SW** input, then close the Battery Charge Protect Switch again to the **BCP SW** input.

**NOTE 4:** See Split Shaft Mode Description.

Reference Ford Body Builder website for year specific information at <https://www.fleet.ford.com/truckbbas/>

## Transmission Overview

### TorqShift® 6R140 Transmission – Stationary Elevated Idle Control (SEIC) (Cont'd) 6.7L Diesel (MY2020-MY2025)/7.3L Gas

#### Models Affected

Medium Duty – MY2020-MY2025

#### SEIC/PTO – General System Behavior

- To guarantee full advertised torque capability at the automatic transmission PTO gear and through the aftermarket PTO clutch, the hydraulic line pressure serving the aftermarket PTO clutch must be elevated. Applying battery voltage to the PTO circuit is the signal to the transmission to enter SEIC strategy and these important functions. This applies to both stationary and mobile PTO operations.
- If an SEIC disabler occurs in any mode:
  - ALL engines will require a "change-of-state", meaning the operator is required to turn off voltage to the "PTO-Request" circuit, and back on again to re-invoke SEIC and PTO operation.
- If the Transmission Oil Temperature (TOT) sensor reaches 240°F, the PTO system may disengage, preventing torque from being delivered to the aftermarket transmission PTO.
- SEIC/PTO strategy function in the PCM is not affected by the loss of vehicle battery electrical power.

#### Engine speed ramp-rates are configurable, by means of an IDS tool, for all powertrains

- Default ramp-rate for all powertrains is 200 RPM/second.
- Configurable ramp rates are as follows:
- Gas: 100–1000 RPM/second (in 100 RPM/seconds increments).
- The SEIC system offers buffered PCM voltage and ground circuits to complete the resistor circuits for engine speed.
- If there is a high electrical demand on the chassis battery, such as from aftermarket inverters or generators, etc., the actual elevated idle engine speed may vary with that demand for any given resistance in the SEIC circuit.

#### Correlation between engine speed and resistor values:

- The 7.3L gasoline applications uses a 5VDC reference signal and ground for the PTO\_RPM input circuit.
- Normal base engine calibration allows approximately +/-50 RPM fluctuation. If any factory vehicle accessories are used during SEIC, e.g. A/C, defroster, etc., then that fluctuation may increase to approximately +/-100 RPM or more.
- The sudden loss of aftermarket PTO hydraulic pressure during SEIC/PTO operation, like a ruptured hose, may send SEIC engine speed to near 3000 RPM. It is recommended that a hydraulic pressure switch linked to SEIC/PTO be added to disable SEIC/PTO when a hose ruptures.
- Because of a service brake circuit characteristic at engine-start, invoking SEIC may cause the diagnostic error code FFG\_BOO to get flagged (recorded in the PCM). To avoid this, simply tap the service brake pedal sometime after engine-start and prior to invoking SEIC. Once the code is set, SEIC may not be available until it is erased.

Reference Ford Body Builder website for year specific information at <https://www.fleet.ford.com/truckbbas/>



# 249/249V Series

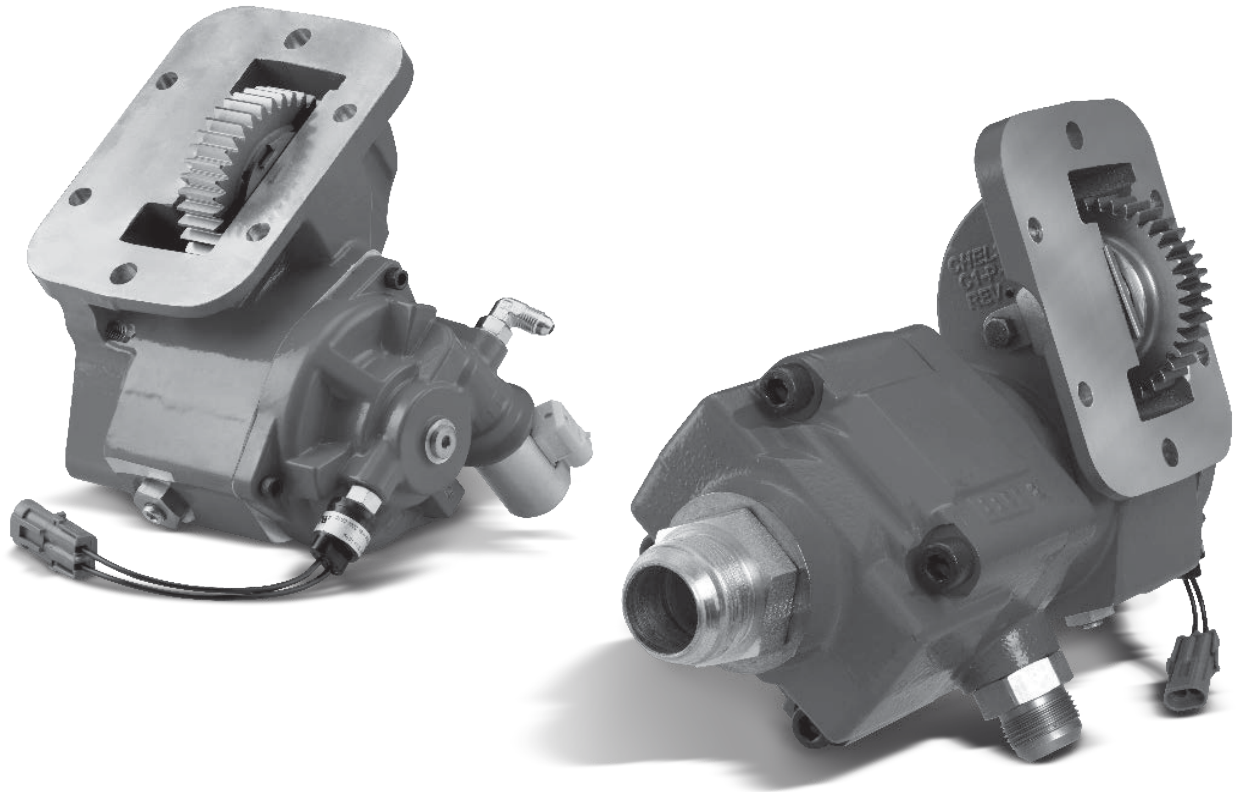

## FORD TorqShift® 6R140 Transmission

**Super Duty F-250-F-550  
6.7L Diesel MY2011-MY2019  
6.2L/6.8L Gas MY2017-MY2019**

**Medium Duty F-650/F-750  
6.7L Diesel MY2016-MY2025  
6.8L Gas MY2013-MY2019  
7.3L Gas MY2020-MY2025**

## Super Duty F-250-F-550 – MY2011-MY2019 – 6.7L Diesel Medium Duty F-650/F-750 – MY2016-MY2025 – 6.7L Diesel In-Cab PTO Switch Installation

**NOTE:** Before starting installation of the electrical wiring:

1. Disconnect the battery cables from the battery and secure to prevent accidental contact.
2. Locate a position in the cab for mounting the PTO switch and mounting bracket. The shaded area in **(Fig. 3)** shows the Occupant Protection Zone of the deployed air bags that are available in these vehicles.

**WARNING:** To avoid personal injury or equipment damage: **DO NOT** install any item from a Chelsea Power Take-Off (i.e.: PTO switch or mounting bracket) in the Occupant Protection Zone.

**CAUTION:** Before drilling any holes, make sure there is adequate clearance on both sides.

For electrical installation see installation sketch on [page 39](#) for non-EOC and [page 45](#) for EOC.

3. Locate the Ford wiring to be connected to the Chelsea PTO harness.
  - a. MY2017-MY2018 F-250-F-550 blunt cut wires located at passenger side kick panel.
  - b. All Others - Ford wiring is located behind the customer access panel located directly under the steering column **(Fig. 4)**.
4. After determining the location of the PTO switch, run wiring assembly over to the area of the blunt cut wires. You are now ready to attach the wires from the Chelsea wiring harness to the Ford wires.

**NOTE:** For MY2017-MY2018 F-250-F-550, all necessary wires are in the Ford wiring harness.

**WARNING:** Ensure all fasteners and fittings are torqued according to their manufacturer's specification.

**!** This symbol warns of possible personal injury.

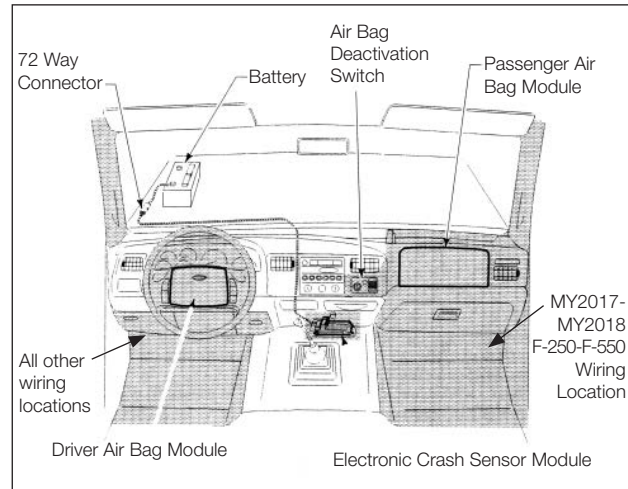

Figure 3

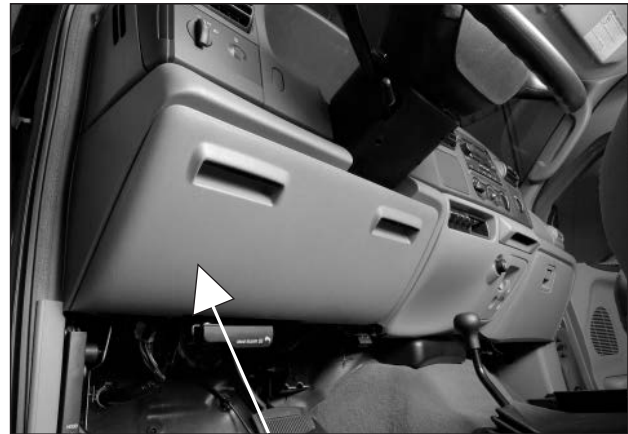

Figure 4

**Customer Access Panel**

## Super Duty F-250-F-550 – MY2011-MY2019 – 6.7L Diesel (Cont'd) Medium Duty F-650/F-750 – MY2016-MY2025 – 6.7L Diesel In-Cab PTO Switch Installation

- Connect the Chelsea wiring harness to the FORD blunt cut wires per the wiring chart on [page 40 and 46](#). Butt connectors are provided on the Chelsea wiring harness (**Fig. 5**).

### Splice/Repair

When necessary to splice wire for repair or circuit length revisions, the following guide should be followed:

- Wire ends should be stripped making sure that individual conductor strands are not damaged.
- When soldering, make sure an adequate mechanical joint exists before applying solder. Use only rosin core solder — never acid core.
- For crimp joints, use butt-type metal barrel fasteners and a proper tool (such as Motorcraft crimp tool S-9796) specifically designated for this type of work.
- Splice joints must be adequately sealed and insulated. Adhesive-lined heat shrink tubing is highly recommended to cover soldered and bare metal barrel crimp joints.
- The most durable splice joint will be bare metal barrel crimped, flow-soldered and covered with adhesive lined heat shrink tubing. This is recommended as the preferred splice joint.

**NOTE:** It is important to remember that a solid electrical connection is essential when installing any electrical device or option. A proper crimp is shown in (**Fig. 7**).

- Attach the ground wire Black with ring terminal (3/8") on its end to a confirmed ground location (**Fig. 6**). Reference Wiring Charts on [page 40 or 46](#) of this manual.
- Find a suitable location to route the wiring harness out of the cab area and to the location of the manifold. Make sure wiring is clear of driveline and exhaust. See [page 39 and 45](#) for information.



Figure 5



Figure 6

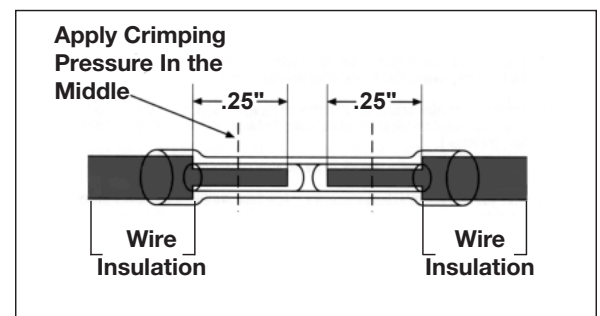

Figure 7

**CAUTION:** A battery voltage to the Diesel "PTO" wire is what the transmission looks for to initiate commands. Failing to do so may show up as low or oscillating hydraulic line pressure and low or no PTO torque or pump flow output. Any attempt to operate the Power Take-Off at elevated idle without these commands may result in under-capacity PTO clutch wear, resulting in rapid contamination of transmission fluid, and internal transmission damage. This applies to both stationary and mobile automatic transmission PTO operations. Reference Wiring charts on [pages 40 or 46](#).

**NOTE:** Chelsea Wiring Harness includes a potentiometer factory set to Maximum Resistance which defaults to the minimum engine RPM established by Ford. See [pages 82-84](#) for more information.

## Super Duty F-250-F-550 – MY2017-MY2019 – 6.2L/6.8L Gas

### Medium Duty F-650/F-750 – MY2013-MY2019 – 6.8L Gas

### Medium Duty F-650/F-750 – MY2020-MY2025 – 7.3L Gas

#### In-Cab PTO Switch Installation

**NOTE:** Before starting installation of the electrical wiring:

1. Disconnect the battery cables from the battery and secure to prevent accidental contact.
2. Locate a position in the cab for mounting the PTO switch and mounting bracket. The shaded area in **(Fig. 8)** shows the Occupant Protection Zone of the deployed air bags that are available in these vehicles.

**! WARNING:** To avoid personal injury or equipment damage: Do not install any item from a Chelsea Power Take-Off (i.e.: PTO switch or mounting bracket) in the Occupant Protection Zone.

**CAUTION:** Before drilling any holes, make sure there is adequate clearance on both sides.

For electrical installation see installation sketch on [page 41](#) for non-EOC.

3. Locate the Ford wiring to be connected to the Chelsea PTO harness.
  - a. MY2017-MY2018 F-250-F-550 blunt cut wires located at passenger side kick panel.
  - b. All Others - Locate and remove the customer access panel located directly under the steering column **(Fig. 10)**.
4. Run the wiring assembly over to the area of the located Ford wiring. You are now ready to attach the wires from the Chelsea wiring harness.
5. Next locate the Ford ignition switch wire. Connect the Chelsea 12VDC wire to the Ford ignition wire **(Fig. 11)**.

**NOTE:** For F-250-F-550 MY2017-MY2019, all necessary wires are in the Ford wiring harness.

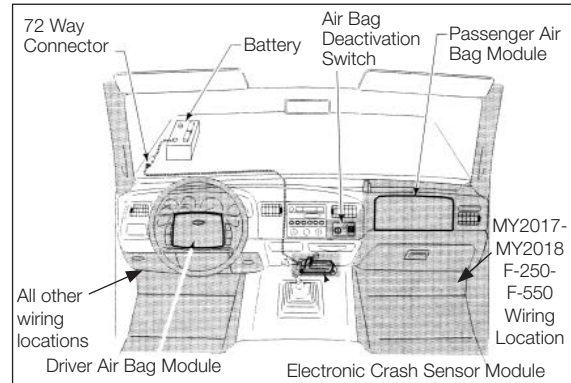

Figure 8

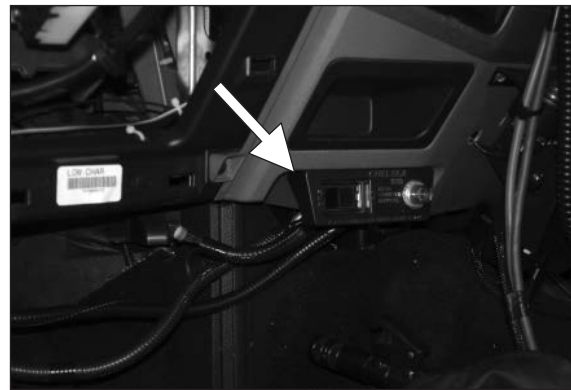

Figure 9



Figure 10



Figure 11

**! This symbol warns of possible personal injury.**

**Super Duty F-250-F-550 – MY2017-MY2019 – 6.2L/6.8L Gas (Cont'd)**  
**Medium Duty F-650/F-750 – MY2013-MY2019 – 6.8L Gas**  
**Medium Duty F-650/F-750 – MY2020-MY2025 – 7.3L Gas**  
**In-Cab PTO Switch Installation**

- Remove the kick panel in front of the door just above the floor board for F-650/F-750 only (**Fig. 12**).
- Connect the Chelsea Black wire w/ring connector (3/8") to the Ford ground screw that is located in an area that is paint free (**Fig. 13**).

**NOTE:** Chelsea Wiring Harness includes a potentiometer factory set to Maximum Resistance. See [pages 80-82](#) for more information.

### Splice/Repair

When necessary to splice wire for repair or circuit length revisions, the following guide should be followed:

- Wire ends should be stripped making sure that individual conductor strands are not damaged.
- When soldering, make sure an adequate mechanical joint exists before applying solder. Use only rosin core solder — never acid core.
- For crimp joints, use butt-type metal barrel fasteners and a proper tool (such as Motorcraft crimp tool S-9796) specifically designated for this type of work.
- Splice joints must be adequately sealed and insulated. Adhesive-lined heat shrink tubing is highly recommended to cover soldered and bare metal barrel crimp joints.
- The most durable splice joint will be bare metal barrel crimped, flow-soldered and covered with adhesive lined heat shrink tubing. This is recommended as the preferred splice joint.

**NOTE:** It is important to remember that a solid electrical connection is essential when installing any electrical device or option. A proper crimp is shown in (**Fig. 14**).

- Find a suitable location to route the blunt cut and PTO connector wiring harnesses out of the cab area.

### F-650/F-750 only

- MY2013-MY2019, the Ford SEIC blunt-cut customer service wires are located under hood, on the right (passenger) side of the engine compartment, below the cowl (**Fig. 15**).
- For MY2020-MY2025 the SEIC circuits are located under hood on driver's side.



Figure 12

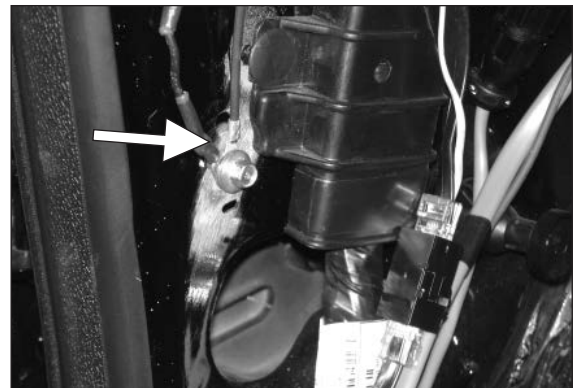

Figure 13

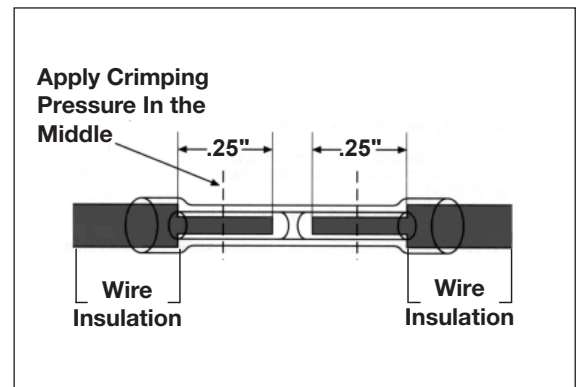

Figure 14

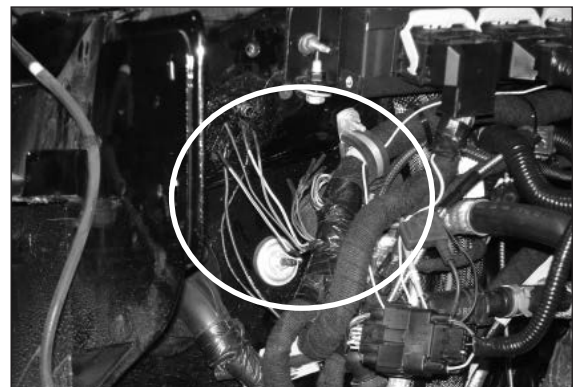

Figure 15

## Mounting the PTO

### PTO Installation – Overview

1. Refer to [pages 32-37](#) of this manual for PTO installation.
2. PTO installation is the same basic installation as on the Ford Super Duty Vehicles. But, on the 6.8L gas, a heat shield is required to protect the PTO and accessories such as the PTO electrical wiring and the transmission-to-PTO hydraulic hose.
3. Hose Routing – It is critical that the hose be routed to ensure it does not touch the exhaust.
  - The PTO fitting should be indexed at 90-degrees and the transmission fitting indexed at 45-degrees. Route the hose as shown in **(Fig. 16)**.
4. Electrical – Solenoid and pressure switch connections.
  - Route the wiring harness with heat resistant wire guard to connect the solenoid and pressure switch. Position so the harness is not in contact with the exhaust pipe. Zip tie the harness to the Ford shift linkage cable after the connections to the PTO are complete.

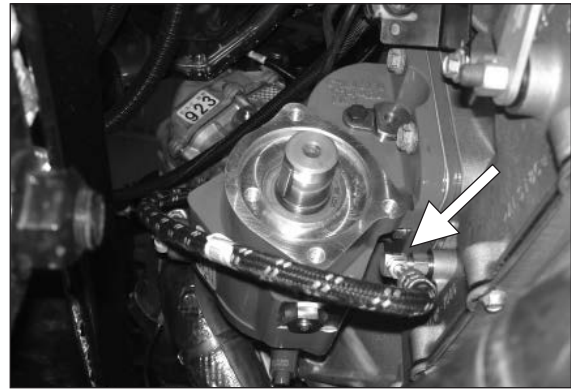

Figure 16

### PTO Installation – Pre-work

**CAUTION:** When installing the PTO, always wear protective clothing and safety glasses.

**Overview:** The 249 Series comes in two main sections.

1. A geared adapter section (**Fig. 17**).
2. Main PTO housing. This unique design allows for time saving installation on both 4x2 and 4x4 Super Duty applications (**Fig. 18 and Fig. 19**).

**NOTE:** There are two split dowels that will act as guides when installing the adapter to the transmission. These come pre-installed in the adapter (**Fig. 20**).



Figure 17

249 Series  
Figure 18249V Series  
Figure 19

Figure 20

**Mounting the PTO (Cont'd)**

**IMPORTANT:** MY2017-MY2018 F-250-F-550 4x4 with manual transfer case shifter - the manual shift cable has a bracket connected to the PTO aperture that needs to be relocated as it will interfere with PTO installation. Contact your local Ford Dealer or Ford Body Builders Advisory Service at 877-840-4338 or <https://www.fleet.ford.com/truckbbas/>

**NOTE:** Dropping the 4WD auxiliary shaft will provide more room for installation but it is not required for all applications.

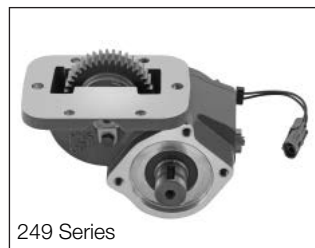
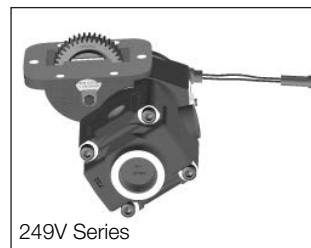
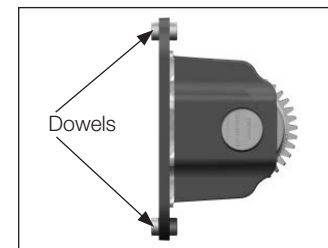
**NOTE:** The removal of the transmission electrical connection plug will aid in the installation of the PTO (**Fig. 21**) (**249V**).

**This transmission does not require the oil to be drained for the PTO installation, but expect some oil to weep when covers and plugs are removed.**

**! WARNING:** Oil may be hot. Use extreme caution to assure that you do not accidentally come in contact with hot oil.

3. Remove the plug from the transmission pressure port (**Fig. 22**) and install fitting in the opening (**Fig. 23**).

**IMPORTANT:** Both Washers and the O-ring must be present at installation. The second Washer must fit around the O-ring for proper seal (**Fig. 23**).

**PTO Pressure/Lube Fitting & Hose:**

380750 90-degree Adapter Fitting (1 each) (**Fig. 23**).  
329130-3X Hose Assembly (1 each) (**Fig. 24**).

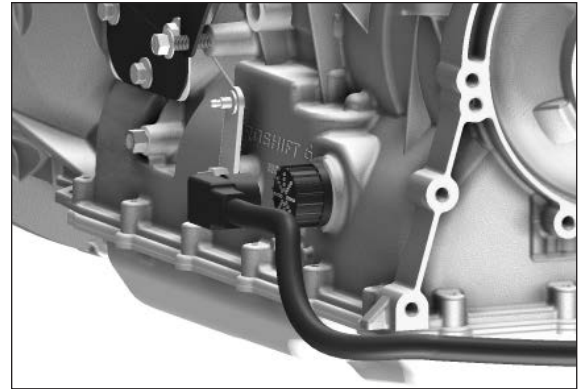

Figure 21

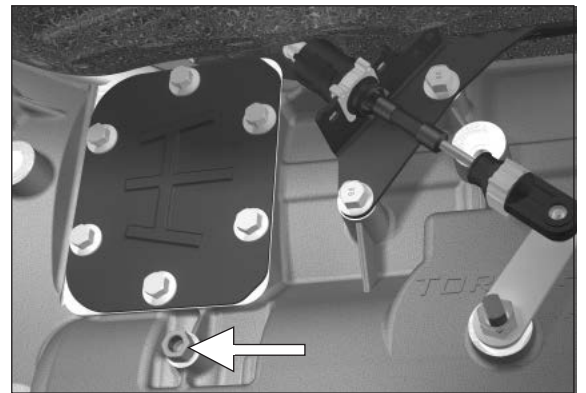

Figure 22

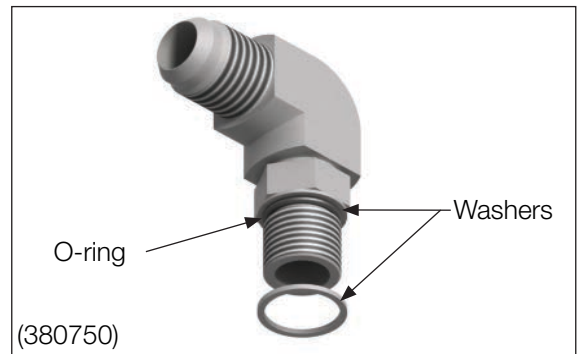

Figure 23

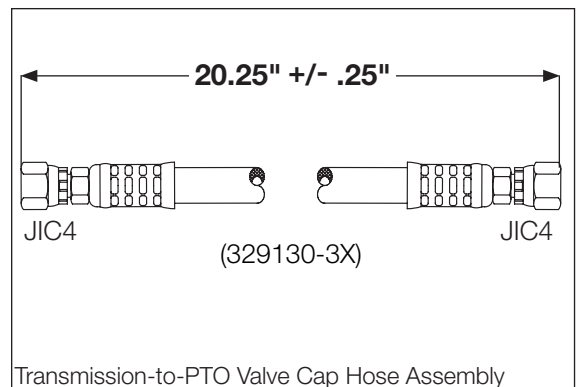

Figure 24

**! This symbol warns of possible personal injury.**

249/249V Series Installation Instructions

Mounting the PTO (Cont'd)

- Remove the PTO aperture cover plate and gasket (Fig. 25 and Fig. 25a). **DO NOT** discard the gasket. It will be used when installing the adapter on the transmission.

**IMPORTANT:** Inspect the gasket for rips, tears, and deformities that may cause leaks. If there are any questions about the integrity of the gasket, replace with a new gasket. If the gasket needs to be replaced, order Chelsea PN 22-P-124. **DO NOT** use any other gasket material than that supplied by Ford or Chelsea specific for the 6R140 transmission.

**NOTE:** PTO installation may be easier if the shifter lever and bracket are removed. Hold PTO in position to see if the PTO/Pump can be installed without removing the transmission shifter. If shifter or bracket needs to be removed (see pages 87-90) (249V).

- Six fasteners (Fig. 26 or Fig. 27) are used to attach the PTO to the transmission opening.

**NOTE:** Do not use sealing compounds because they are generally incompatible with automatic transmission fluids and could possibly contaminate valve bodies in the transmission.

- 249** - Install the three studs from stud kit (Fig. 26). Install the two longer studs at 12 O'clock and 6 O'clock and the shorter stud at the 8 O'clock location on the transmission aperture pad (Fig. 28).

**249V** - Install the six studs from stud kit (Fig. 27). Install the two shorter studs at 4 O'clock and 8 O'clock and the longer studs in the other locations on the transmission aperture pad.

**CAUTION: Over tightening of the studs or running the shoulder past the transmission mounting surface may damage stud and/or transmission threads (249).**

- 249** - Install the three studs until the shoulder of the stud is flush with the transmission mounting surface.

**249V** - Tighten the stud and torque to 17-19 lb-ft [23-26 N-m].

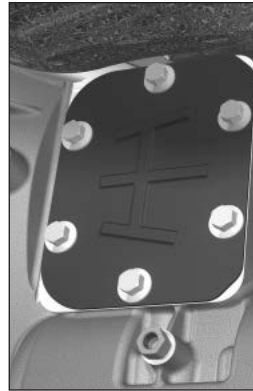

Figure 25

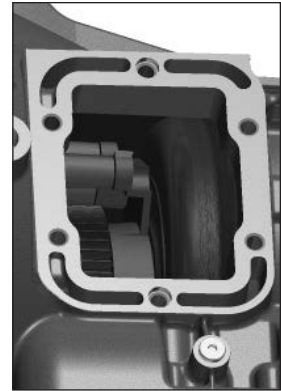

Figure 25a

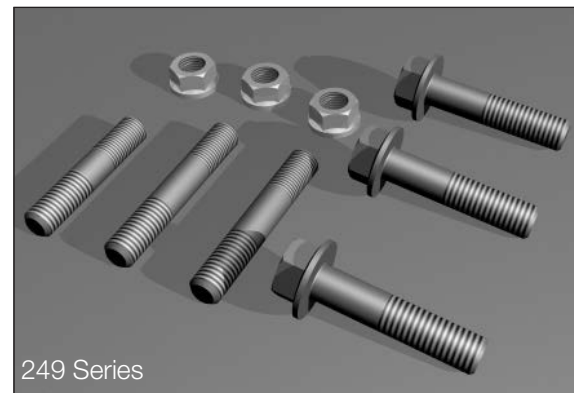

Figure 26



Figure 27

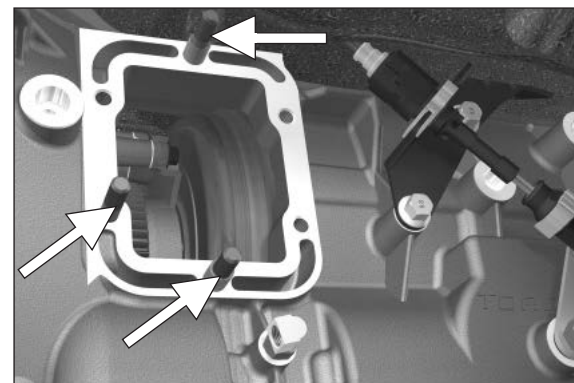

Figure 28

## Mounting the PTO (Cont'd)

**CAUTION: Overtightening of the stud may damage stud and/or transmission threads (249V).**

- Slide the gasket supplied with the transmission over the dowel pins on the geared adapter (**Fig. 29**).



Figure 29

- Install the geared adapter into the transmission aperture and over the studs (**Fig. 30**).

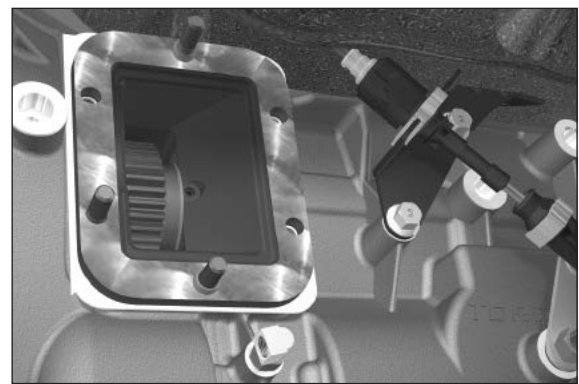

Figure 30

- Install the gasket supplied with the PTO over the studs and against the geared adapter (**Fig. 31**).

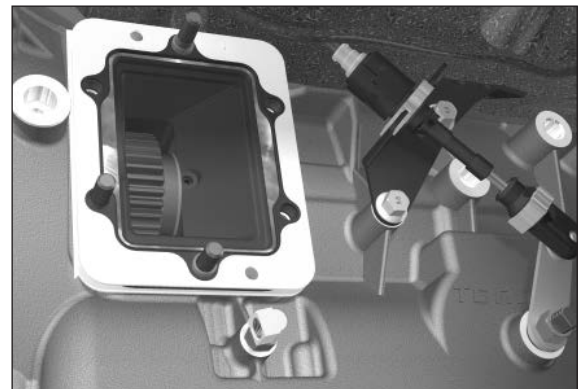

Figure 31

- Install the PTO over the studs and attach the self-locking nuts to the top shoulder stud and left top shoulder stud. **DO NOT** tighten down at this time (**Fig. 32**).

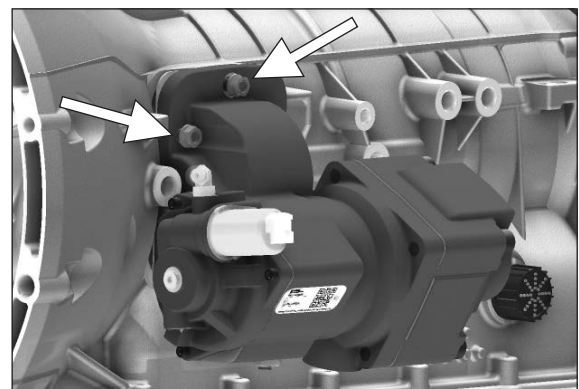

Figure 32

**Mounting the PTO (Cont'd)**

12. Install the bottom two self-locking nuts. **DO NOT** tighten down at this time (**Fig. 33**).

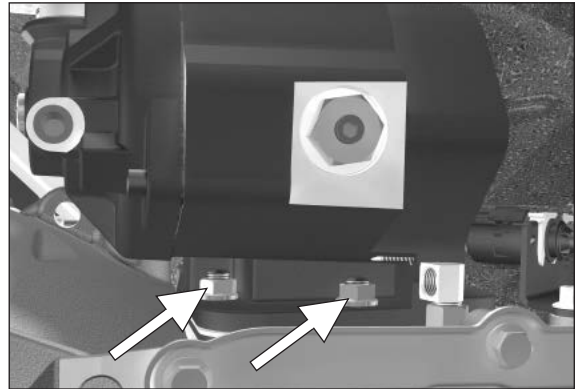

Figure 33

13. **249** - Next, install the three remaining hex cap screws in the remaining holes (**Fig. 34**).

**249V** - Next, install the two remaining locking nuts on the top and middle right side studs (**Fig. 34**).

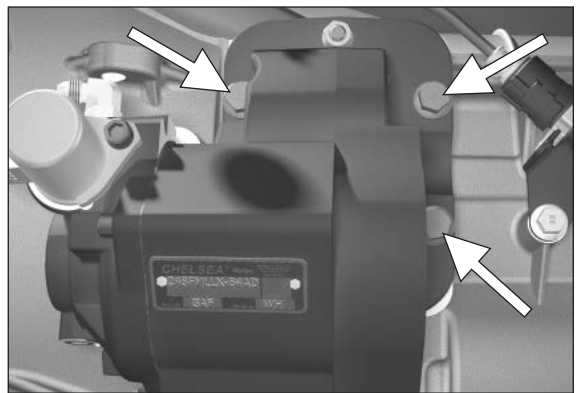

Figure 34

14. Torque all cap screws (**Fig. 35**) to 25 lb-ft [34 N-m] and torque the self-locking nuts to 35-40 lb-ft [48-54 N-m].

**NOTE:** Always torque fasteners in a crossing pattern (**Fig. 35**).

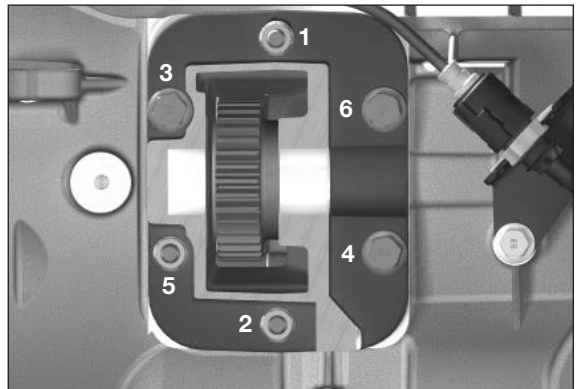

Figure 35

15. Connect hose (Transmission-to-PTO Valve) to the fitting on the transmission. Route as shown in **Fig. 36**. Hold hose fitting in desired position and tighten lock nut with a wrench until solid feeling is encountered. From that point, apply one-sixth turn. Next, connect the other end of the hose to fitting on the PTO valve cap. Tighten until solid feeling is encountered. From that point, apply one-sixth turn.

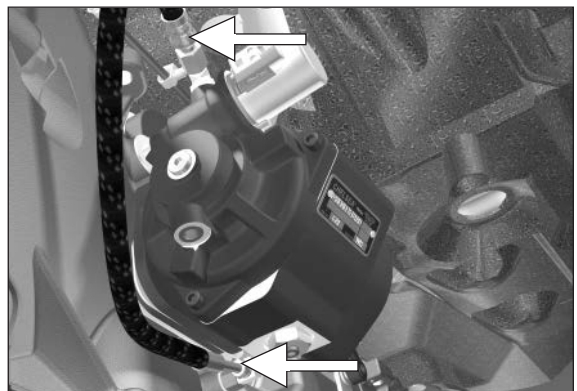

Figure 36

**! WARNING:** Oil may be hot. Use extreme caution to assure that you do not accidentally come in contact with hot oil.

**! This symbol warns of possible personal injury.**

## Mounting the PTO (Cont'd)

16. Install the PTO pressure switch onto port on the Hydraulic Valve Cap. Torque to 10-12 lb-ft [13.56-16.27 N-m] (**Fig. 37**).
  17. Connect wiring harness as shown on [pages 39-46](#).
  18. If installing a Chelsea Pump, see [page 52](#) for pump installation and bolt torque specifications (**249**).
  19. Reinstall the transmission electrical connection plug. Verify that the connector has a tactile click when reinstalling the connector. Failure to properly reinstall the connector can lead to transmission issues (**Fig. 38**) (**249V**).
  20. Connect hydraulic hoses to pump inlet and pressure ports. Fill hydraulic tank with recommended hydraulic oil. Follow start up instructions on [page 48](#).
- 249V Pump Porting**  
Inlet = SAE 24 ORB  
Pressure = SAE 16 ORB

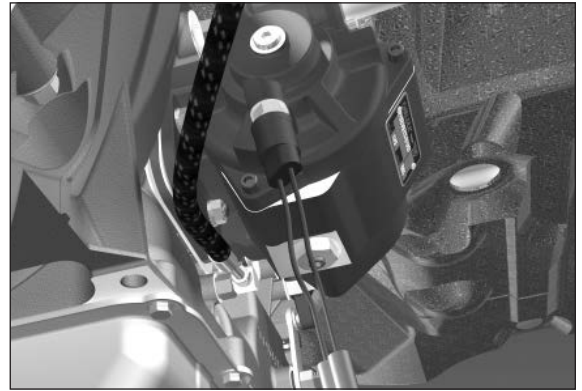

Figure 37

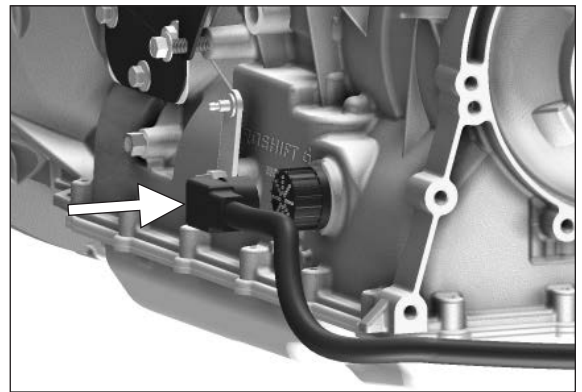

Figure 38

**CAUTION: DO NOT** start engine with 249V PTO and pump installed unless hydraulic system is connected and filled with oil. Failure to follow these instructions may result in PTO and pump damage.

## Heat Shield Installation

Instructions for installing the Heat Shield are located in the Appendix on [page 85](#).

**Medium Duty F-650 – MY2013-MY2015 – 6.8L Gas  
 249G Special Installation Instructions**

**Wiring Outside the Cab – Engine Compartment**

1. Route the Chelsea blunt-cut wiring harness along the Ford main wiring harness in the engine compartment fire wall to the Ford blunt-cut SEIC customer access circuits (**Fig. 39**).
2. See [pages 41 and 42](#) for complete blunt-cut wiring instructions.
3. Route the PTO solenoid connection and pressure switch connection wires parallel to the transmission linkage cable.
4. Make sure wiring is clear of driveline and exhaust.

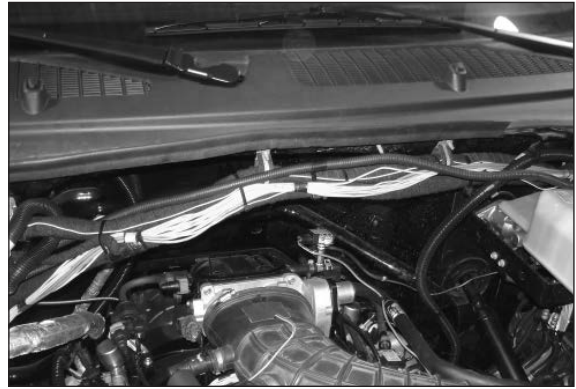

Figure 39

**Potentiometer Settings**

Charts are located in the Appendix on [pages 82-84](#).

CHASSIS	FUEL	MY2009	MY2010	MY2011	MY2012	MY2013	MY2014	MY2015	MY2016	MY2017-MY2019	MY2020
Super Duty F-250-F-550	Gas	Chart I	Chart I	Chart I	Chart I	Chart I	Chart I	Chart I	Chart III	Chart IV	
	Diesel	Chart I	Chart I	Chart II	Chart II	Chart II	Chart II	Chart II	Chart III	Chart IV	
Medium Duty F-650/F-750	Gas				Chart I	Chart I	Chart I	Chart I	Chart III	Chart IV	Chart V
	Diesel								Chart III	Chart IV	Chart V

**Hose Assembly Identification Chart**  
**249F**

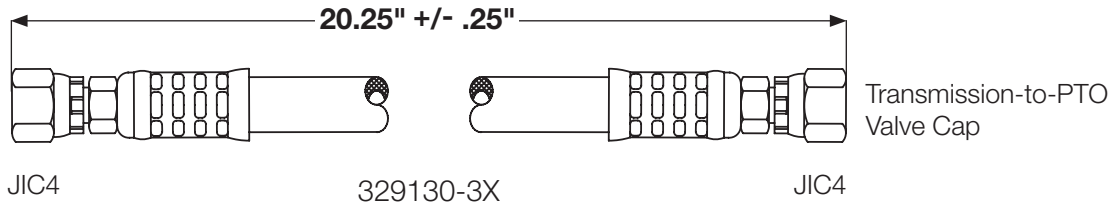

**Wiring Installation (Shift Option B)**  
**Super Duty F-250/F-550 – MY2011-MY2019 – 6.7L Diesel**  
**Medium Duty F-650/F-750 – MY2016-MY2025 – 6.7L Diesel**  
**249F w/o Electronic Overspeed Control (EOC)**

(SK-490 Rev G)

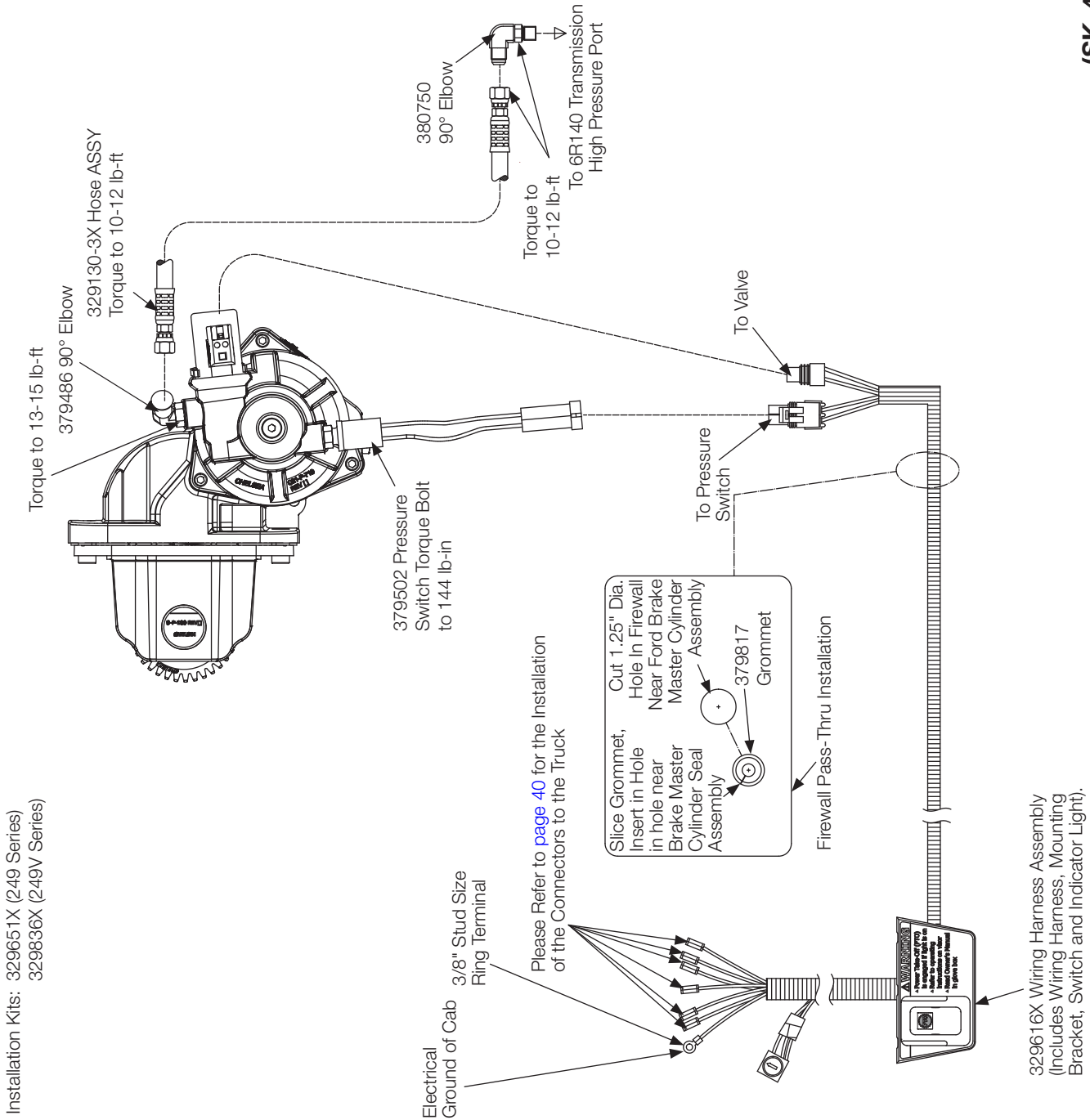

**Wiring Installation Chart (Shift Option B)**

(SK-490 Rev G)

**Super Duty F-250-F-550 – MY2011-MY2019 – 6.7L Diesel**  
**Medium Duty F-650/F-750 – MY2016-MY2025 – 6.7L Diesel**  
**249F w/o Electronic Overspeed Control (EOC)**

Super Duty F-250-F-550							
Chelsea PTO Wire Harness		2011-2016 - Drive Side behind Data Link 2017-2019 - Passenger Side Kick Panel					
		Stationary Mode			Mobile Mode		
		Function	Ford Wire Color	Circuit	Function	Ford Wire Color	Circuit
329616X Wiring Harness	Purple	12VDC Power	2011-2016 <sup>(2)</sup> White/Blue	#CDC64	12VDC Power	2011-2016 <sup>(2)</sup> White/Blue	#CDC64
			2017-2018 Green/Orange	#CBP22		2017-2018 Green/Orange	#CBP22
	Yellow	PTO REQ1	Yellow/Green	#CE912	PTO REQ1	NOT USED	#CE912
		PTO REQ2	NOT USED	#CE933	PTO REQ2	Blue/Orange <sup>(1)</sup>	#CE933
	White	PTO VREF	White/Brown	#LE434	PTO VREF	White/Brown	#LE434
	Green	PTO RPM	Green	#CE914	PTO RPM	Green	#CE914
Grey	PTO RTN	Grey/Violet	#RE327	PTO RTN	Grey/Violet	#RE327	
	Blue/White	PTO RELAY	Blue/White	#CE326	PTO RELAY	Blue/White	#CE326

**NOTE:**  
<sup>(1)</sup> Early MY2011 Product Units may come with two Blunt Cut Blue/Grey Stripe wires. One wire will be for PTO Function (PTORS2) the other will be a Customer Wire for "Park Only Output" (TRO-P). Refer to Ford Body Builders web site for more on this subject.  
<sup>(2)</sup> For Trucks built after May 15, 2010. Trucks built prior to May 15, 2010 this Ford wire is Yellow/Orange Stripe. See Appendix for more year specific wiring information.

Medium Duty F-650/F-750							
Chelsea PTO Wire Harness		Driver Side behind Data Link					
		Stationary Mode			Mobile Mode		
		Function	Ford Wire Color	Circuit	Function	Ford Wire Color	Circuit
329616X Wiring Harness	Purple	12VDC Power	2016-2019 Yellow/Grey	#CBB35	12VDC Power	2016-2019 Yellow/Grey	#CBB35
			2020-2025 Grey	#CBK03		2020-2025 Grey	#CBK03
	Yellow	PTO REQ1	Yellow/Green	#CE912	PTO REQ1	NOT USED	#CE912
		PTO REQ2	NOT USED	#CE933	PTO REQ2	2016 <sup>(3)</sup> - Blue/Orange 2017-2019 - Blue/Red 2020-2021 - Blue/Green 2025 - Blue/Orange	#CE933
	White	PTO VREF	White/Brown	#LE434	PTO VREF	White/Brown	#LE434
	Green	PTO RPM	Green	#CE914	PTO RPM	Green	#CE914
Grey	PTO RTN	Grey/Violet	#RE327	PTO RTN	Grey/Violet	#RE327	
	Blue/White	PTO RELAY	2016-2019 Blue/White 2020-2025 Blue/Grey	#CE326 #CE326	PTO RELAY	2016-2019 Blue/White 2020-2021 Blue/Grey 2025 - Blue/White	#CE326

**NOTE:** <sup>(3)</sup> Blue w/ orange prior to March 2016. Blue/Red after March 2016. See Appendix for more year specific wiring information.

**Mobile to Stationary Switch**

- If required for your application a Single Pole Double Throw (SPDT) switch can be installed in the cab to control PTO function between Mobile Mode and SEIC Stationary Mode. Connect the Chelsea YELLOW wire as illustrated below.

**Switching Between Stationary and Mobile**

To switch between Mobile & Stationary Mode – Install a Single Pole Double Throw (SPDT) switch as shown:

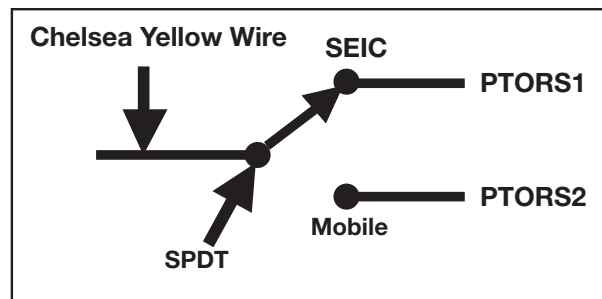

**Hose Assembly Identification Chart**  
**249G**

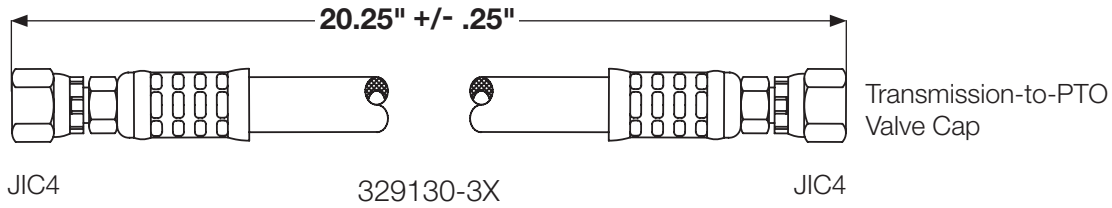

**Wiring Installation (Shift Option B)**  
**Medium Duty F-650 – MY2013-MY2015 – 6.8L Gas**  
**249G w/o Electronic Overspeed Control (EOC)**

(SK-560 Rev D)

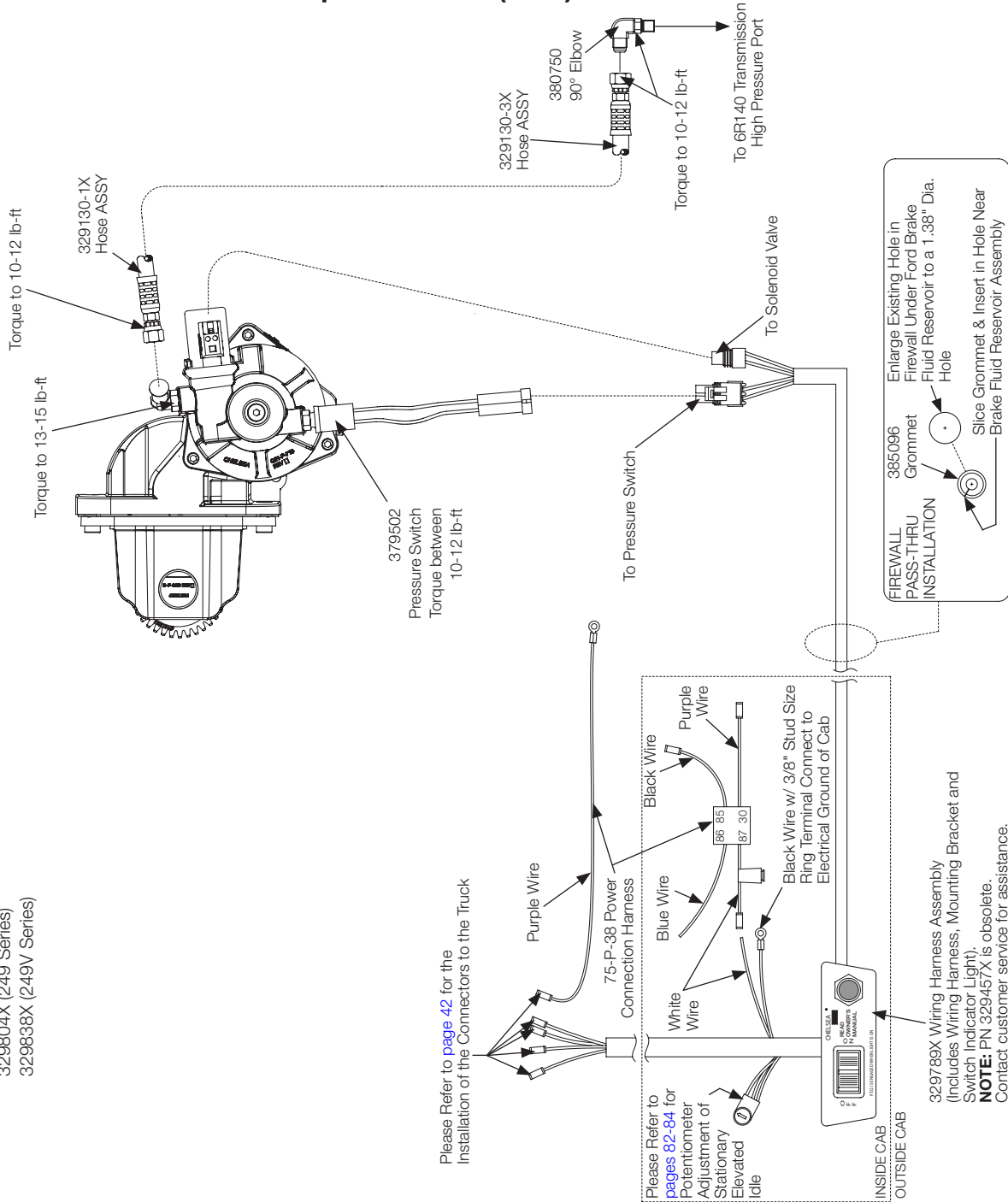

Installation Kits: 329789X (Included)  
329804X (249 Series)  
329838X (249V Series)

Please Refer to page 42 for the Installation of the Connectors to the Truck

Please Refer to pages 82-84 for Potentiometer Adjustment of Stationary Elevated Idle

329789X Wiring Harness Assembly (Includes Wiring Harness, Mounting Bracket and Switch Indicator Light).  
**NOTE:** PN 329457X is obsolete. Contact customer service for assistance.

**Wiring Installation Chart (Shift Option B)  
Medium Duty F-650 – MY2013-MY2015 – 6.8L Gas  
249G w/o Electronic Overspeed Control (EOC)**

(SK-560 Rev D)

**Wiring Interface Configurations**

Chelsea PTO Wire Harness		Stationary Mode (Mobile Mode Not Available)		
		Function	Ford Wire Color	Circuit
<b>75-P-38 Power Connection Harness</b>	<b>Under Hood</b>			
	Purple w/ Butt Connector (80")		Violet/Yellow	#870
	Purple w/ Ring Terminal (80")		Battery Junction Box Battery Connection Post	
	<b>Under Dash</b>			
	Black		Ford Ground Circuit Black	#57
	Blue		12VDC Blue/Green	
	Purple		Violet/Yellow	#870
	White		Chelsea White Wire on 329789X Main Harness	

<b>329789X Main Harness</b>	<b>Under Hood</b>			
	Green	PTO RPM	Ford Circuit (Green)	#CE914
	Blue/White	PTO RLY	Ford Circuit (Blue/White)	#CE326
	Blue	PTO REQ2	Blue/Orange or Blue/Red (effective March 2016)	#CE933
	Yellow	PTO REQ1	Yellow/Green	#CE912
	<b>Under Dash</b>			
Black w/ Ring Terminal		Chassis Ground In Dash		

See Appendix for more year specific wiring information.

**Hose Assembly Identification Chart  
249H**

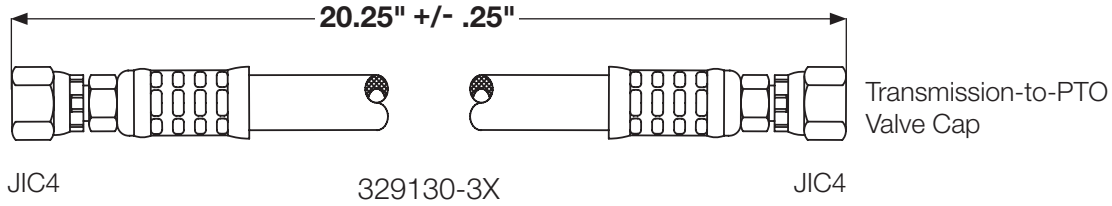

**Wiring Installation (Shift Option B)  
 Super Duty F-250/F-550 – MY2017-MY2019 – 6.2/6.8L Gas  
 Medium Duty F-650/F-750 – MY2016-MY2019 – 6.8L Gas  
 Medium Duty F-650/F-750 – MY2020-MY2025 – 7.3L Gas  
 249H w/o Electronic Overspeed Control (EOC)**

**(SK-490 Rev G)**

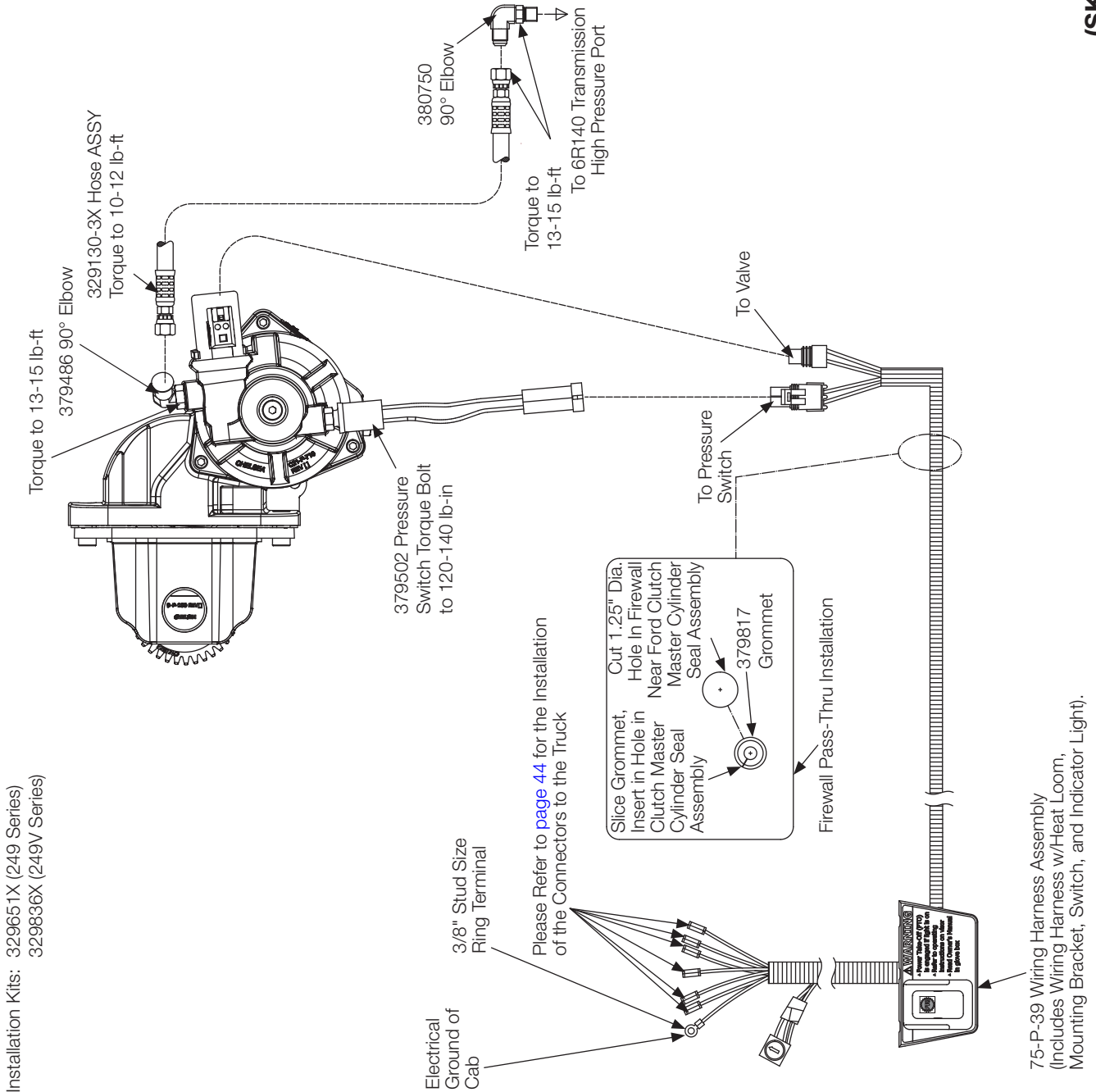

Installation Kits: 329651X (249 Series)  
329836X (249V Series)

**Wiring Installation Chart (Shift Option B)**

(SK-490 Rev G)

**Super Duty F-250-F-550 – MY2017-MY2019 – 6.2/6.8L Gas**

**Medium Duty F-650/F-750 – MY2016-MY2019 – 6.8L Gas**

**Medium Duty F-650/F-750 – MY2020-MY2025 – 7.3L Gas**

**249H w/o Electronic Overspeed Control (EOC)**

Super Duty F-250-F-550 – (starting w/ MY2017)							
Chelsea PTO Wire Harness		Passenger Side Kick Panel					
		Stationary Mode			Mobile Mode		
		Function	Ford Wire Color	Circuit	Function	Ford Wire Color	Circuit
75-P-39 Wiring Harness	Yellow/Grey	12VDC Power	Green/Orange	#CBP22	12VDC Power	Green/Orange	#CBP22
	Yellow/Blue	PTO REQ1	Yellow/Green	#CE912	PTO REQ1	NOT USED	#CE912
		PTO REQ2	NOT USED	#CE933	PTO REQ2	Blue/Orange	#CE933
	Yellow/Green	PTO VREF	Yellow/Green	#LE424	PTO VREF	Yellow/Green	#LE424
	Green	PTO RPM	Green	#CE914	PTO RPM	Green	#CE914
	Yellow/Violet	PTO RTN	Yellow/Violet	#RE407	PTO RTN	Yellow/Violet	#RE407
Blue/White	PTO RELAY	Blue/White	#CE326	PTO RELAY	Blue/White	#CE326	

**NOTE:** The Blue wire in the Chelsea harness is not used in these model year chassis.

Medium Duty F-650/F-750							
Chelsea PTO Wire Harness		Driver Side behind Data Link					
		Stationary Mode			Mobile Mode <sup>(1)</sup>		
		Function	Ford Wire Color	Circuit	Function	Ford Wire Color	Circuit
75-P-39 Wiring Harness	Yellow/Grey	12VDC Power	2016-2019 - Yellow/Grey 2020-2025 - Grey	#CBB35 #CBK03	12VDC Power	2016-2019 - Yellow/Grey 2020-2025 - Grey	#CBB35 #CBK03
	Yellow/Blue	PTO REQ1	2016-2019 - Yellow/Blue 2020-2025 - Yellow/Green	#CE912	PTO REQ1	NOT USED	#CE912
		PTO REQ2	2016 - Blue/Orange or Red <sup>(2)</sup>	#CE933	PTO REQ2	2016 - N/A 2017 - Blue/Red 2020-2025 - Blue/Orange	#CE933
	Yellow/Green	PTO VREF	Yellow/Green	#LE424	PTO VREF	Yellow/Green	#LE424
	Green	PTO RPM	Green	#CE914	PTO RPM	Green	#CE914
	Yellow/Violet	PTO RTN	Yellow/Violet	#RE407	PTO RTN	Yellow/Violet	#RE407
Blue/White	PTO RELAY	Blue/White	#CE326	PTO RELAY	Blue/White	#CE326	

**NOTE:** The Blue wire in the Chelsea harness is not used in these model year chassis.

**NOTE:** <sup>(1)</sup> Mobile Mode is not available on the 2016 Gas Trucks.

<sup>(2)</sup> Blue/Orange prior to March 2016. Blue/Red after March 2016.

See Appendix for more year specific wiring information.

**NOTE:**

Some early build 2016 6.8L gas F-650/F-750 vehicles have 2 identically colored wires for PTO, which are located in the blunt cut harness under the driver side dash. They are Yellow/Green stripes. Use a voltmeter to identify which circuit you need:

- One wire has 0VDC to ground (PCM Pin C1551B-84 Circuit #CE912).
- One has +5VDC to ground (PTO VREF, PCM Pin 01551B-52 Circuit #LE424).
- Circuit CE912 will be changing to Yellow/Blue in later production.

**NOTE:**

Early build 2016 6.8L gas F-650/F-750 vehicles (built before 10/22/15) have an incorrectly pinned customer access circuit. Circuit #CE326 is pinned in PCM connector #C175B PIN 96. This circuit should be located at PIN 98.

**SYMPTOMS:**

6.8L gas vehicles built before October 22, 2015 and not entering PTO mode due to circuit #CE326 not going to ground when all enabling conditions are met.

**CORRECTIVE ACTION:**

Upfitters and body builders who have a 6.8L gas vehicle built before October 22, 2015 and find that SEIC is exhibiting the symptoms above are advised to contact their local Ford Service center for corrective action per TSB 15-0180. The dealer will be able to determine if this TSB is applicable to the vehicle.

Vehicles built after 10/22/15 will have this circuit in the correct PCM connector cavity.

**Wiring Installation (Shift Option K)**  
**Super Duty F-250-F-550 – MY2011-MY2019 – 6.7L Diesel**  
**Medium Duty F-650/F-750 – MY2016-MY2025 – 6.7L Diesel**  
**Super Duty F-250-F-550 – MY2017-MY2019 – 6.8L Gas**  
**Medium Duty F-650/F-750 – MY2017-MY2019 – 6.8L Gas**  
**Medium Duty F-650/F-750 – MY2020-MY2025 – 7.3L Gas**  
**249F/249H w/ Electronic Overspeed Control (EOC)**

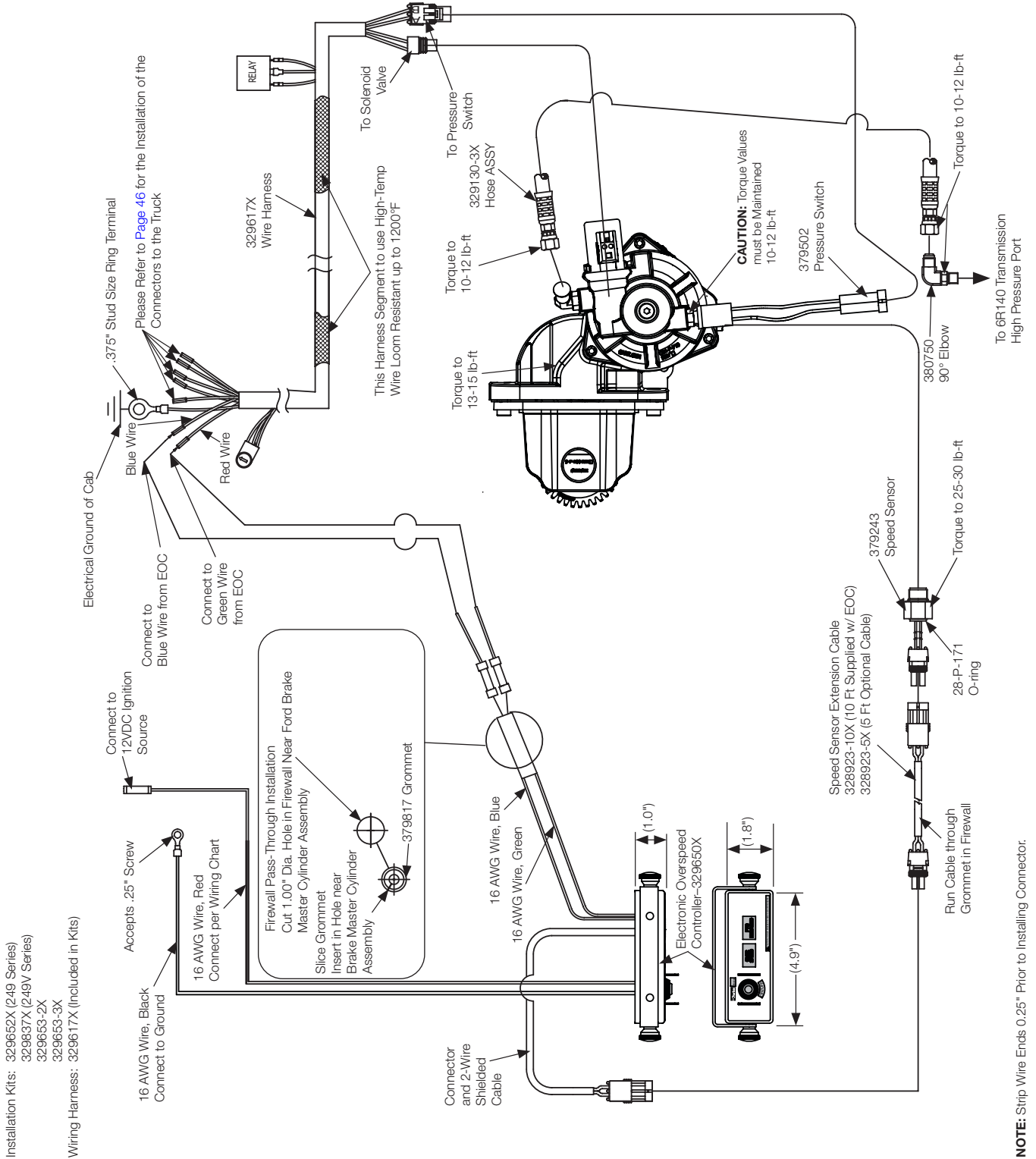

**Wiring Installation Chart (Shift Option K) (SK-489 Rev H)**  
**Super Duty F-250-F-550 – MY2011-MY2019 – 6.7L Diesel**  
**Medium Duty F-650/F-750 – MY2016-MY2025 – 6.7L Diesel**  
**249F w/ Electronic Overspeed Control (EOC)**

Chelsea PTO Wire Harness		Stationary Mode			Mobile Mode		
		Function	Ford Wire Color	Circuit	Function	Ford Wire Color	Circuit
329617X Wiring Harness	White	PTO REF	White/Brown	#LE434	PTO REF	White/Brown	#LE434
	Grey	PTO RTN	Grey/Violet	#RE327	PTO RTN	Grey/Violet	#RE327
	Green	PTO RPM	Green	#CE914	PTO RPM	Green	#CE914
	Blue/White	PTO RLY	2016-2019 - Blue/White 2020-2025 - Blue/Grey	#CE326 #CE326	PTO RLY	2016-2019 - Blue/White 2020-2021 - Blue/Grey 2025 - Blue/White	#CE326
	Black w/ Ring Terminal	Chassis Ground			Chassis Ground		
	Yellow	PTO REQ1	Yellow/Green	#CE912	PTO REQ2	2016 Blue/Orange <sup>(3)</sup> 2017-2019 - Blue/Red 2020-2021 - Blue/Green 2025 - Blue/Orange	#CE933
	Blue	Chelsea EOC Blue Wire			Chelsea EOC Blue Wire		
	Red	Chelsea EOC Green Wire			Chelsea EOC Green Wire		
	<b>NOTE:</b> EOC not available for MY2016 & Prior. <sup>(3)</sup> Blue w/ orange prior to March 2016. Blue/Red after March 2016. Refer to Ford Body Builders website for more on this subject.						

**Wiring Installation Chart (Shift Option K) (SK-489 Rev H)**  
**Super Duty F-250-F-550 – MY2017-MY2019 – 6.8L Gas**  
**Medium Duty F-650/F-750 – MY2017-MY2019 – 6.8L Gas**  
**Medium Duty F-650/F-750 – MY2020-MY2025 – 7.3L Gas**  
**249H w/ Electronic Overspeed Control (EOC)**

Chelsea PTO Wire Harness		Stationary Mode			Mobile Mode		
		Function	Ford Wire Color	Circuit	Function	Ford Wire Color	Circuit
329617X Wiring Harness	White	PTO REF	Yellow/Green	#LE424	PTO REF	Yellow/Green	#LE424
	Grey	PTO RTN	Yellow/Violet	#RE407	PTO RTN	Yellow/Violet	#RE407
	Green	PTO RPM	Green	#CE914	PTO RPM	Green	#CE914
	Blue/White	PTO RLY	Blue/White	#CE326	PTO RLY	Blue/White	#CE326
	Black w/ Ring Terminal	Chassis Ground in Dash			Chassis Ground in Dash		
	Yellow	PTO REQ1	Yellow/Green F-250-F-550 2016-2019 - Yellow/Blue 2020-2025 - Yellow/Green	#CE912	PTO REQ2	2016 N/A 2017-2019 - Blue/Red 2020-2025 - Blue/Orange	#CE933
	Blue	Chelsea EOC Blue Wire			Chelsea EOC Blue Wire		
	Red	Chelsea EOC Green Wire			Chelsea EOC Green Wire		
	<b>NOTE:</b> Early MY2011 Product Units may come with two Blunt Cut Blue w/ Grey Stripe wires. One wire will be for PTO Function (PTORS2) the other will be a Customer Wire for "Park Only Output" (TRO-P). <b>NOTE:</b> EOC not available for MY2016 & Prior. Refer to Ford Body Builders website for more on this subject.						

12VDC Power		Stationary Mode or Mobile Mode			
Chelsea EOC Wire		F-250-F-550		F-650/F-750	
		Ford Wire Color	Circuit	Ford Wire Color	Circuit
Red	2011-2016 12VDC White/Blue <sup>(1)</sup>		#CDC64	2016-2019 - Yellow/Grey	#CBB35
	2017-2019 12VDC Green/Orange		#CBP22	2020-2025 - Grey	#CBK03
	Black w/ Ring Terminal	Ford Chassis Ground in Dash			
<b>NOTE:</b> <sup>(1)</sup> For Super Duty Trucks built after May 15, 2010. Super Duty Trucks built prior to May 15, 2010 this Ford wire is Yellow/Orange. See Appendix for more year specific wiring information.					

### Mounting CGP-P11 Pumps to PTO

The Parker/Chelsea CGP-P11 pumps listed below have a special pump flange designed to mount the pump to the 249 Series PTO without modifying the pump flange. This allows the same pump to be installed on either 4x2 or 4x4 applications.

**NOTE:** Each Chelsea PTO that features a female pump shaft will include a packet of lubricant (part number 379688). Apply this to the male end of the pump shaft before installing the pump to the PTO.

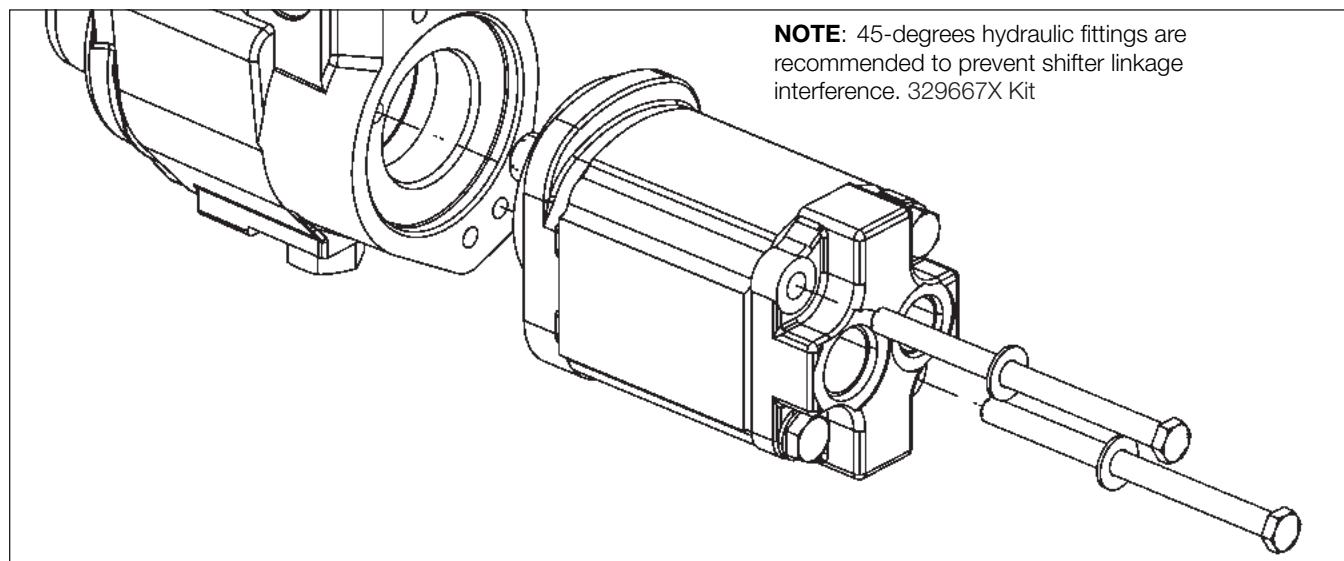

### Chelsea CGP-P11 Series Pump Bolt Specifications - 249 Series

Order Code	Chelsea Pump Model	Pump Tag Number	Pump Mounting Kit	Bolt Number 2 per Pump	Bolt Size	Flat Washer (Qty.)
16	CGP-P11A016-5GC	334 9110 027	329418-2X	378431-31	.375"-16 x 4.250"	500365-26 (2)
26	CGP-P11A026-5GC	334 9110 028	329418-3X	378431-32	.375"-16 x 4.500"	500365-26 (2)
32	CGP-P11A032-5GC	334 9110 068	329665-3X	378431-33	.375"-16 x 4.750"	500365-26 (2)
37	CGP-P11A037-5GC	334 9110 029	329665-3X	378431-33	.375"-16 x 4.750"	500365-26 (2)
42	CGP-P11A042-5GC	334 9110 030	329418-6X	378431-34	.375"-16 x 5.000"	500365-26 (2)
55	CGP-P11A055-5GC	334 9110 031	329418-7X	378431-35	.375"-16 x 5.250"	500365-26 (2)
61	CGP-P11A061-5GE	334 9110 097	329418-8X	378431-36	.375"-16 x 5.500"	500365-26 (2)
71	CGP-P11A071-5GE	334 9110 098	329665-7X	378431-37	.375"-16 x 5.750"	500365-26 (2)
82	CGP-P11A082-5GE	334 9110 099	329665-8X	378431-38	.375"-15 x 6.000"	500365-26 (2)
87	CGP-P11A087-5GE	334 9110 100	329665-8X	378431-38	.375"-15 x 6.000"	500365-26 (2)

**NOTE:** Torque Pump Mounting Bolts between 35-38 lb-ft [48-52 N-m].

**CAUTION:** Failure to Torque pump bolts to the correct specifications may result in poor pump performance and/or premature failure.

**Start-Up Instructions (249V Series Only)**

**General**

All DENISON by Parker vane pumps and motors are individually tested to provide the best quality and reliability. Modifications, conversions, and repairs can only be done by authorized dealers or OEM to avoid invalidation of the guarantee.

The pumps and motors are to be used in the design limits indicated in all the sales bulletins.

Do not modify or work on the pump under pressure or when the engine is on. Qualified personnel are required to assemble and set-up hydraulic devices.

Always conform to regulations (safety, electrical, environment).

The following instructions are important to follow to obtain good service life from the unit.

**Rotation & Ports Indication**

- The rotation and ports orientation are viewed from the shaft end.
- CW stands for clockwise, right-hand rotation.
- CCW stands for counterclockwise, left-hand rotation.

**Start-Up Check-Up**

Check that the assembly of the power unit is correct:

The distance between the suction pipe and the return lines in the tank should be as great as possible.

A bevel on both suction and return lines is recommended to increase the surface and so lower the velocity. We suggest a 45-degree minimum angle.

- Velocities : inlet  $0.5 < x < 1.9$  m/s (1.64 < x < 6.23 ft per second).  
 : return  $x < 6$  m/s (x < 19.7 ft per second).  
 : Always ensure that all return and suction lines are under the oil level to avoid forming aeration or vortex effect. This should be done under the most critical situation (all cylinders extended for example). Straight and short pipes are the best.

$$V = \frac{Q \text{ (Lpm)}}{6 \times \pi \times r^2 \text{ (cm)}} = \text{m/s}$$

$$V = \frac{Q \text{ (GPM)}}{3.12 \times \pi \times r^2 \text{ (in)}} = \text{ft/s}$$

The size of the air filter should be 3 times greater than the maximum instant return flow (all cylinders in movement for example).

DENISON does not recommend inlet strainers. If needed, a 100 mesh (149 microns) is the finest mesh recommended.

Make sure that all protective plugs and covers have been removed.

**Start-Up Instructions (249V Series Only) (Cont'd)**

**Start-up:**

- The tank has been filled up with a clean fluid in proper conditions.
- Flushing the system with an external pump prior to the start-up is good.
- To allow a good priming of the pump, the air should be bled off.
- The first valve on the circuit should be open to tank.
- Air bleed off valves are available on the market place.
- It is possible to bleed off the air by creating a leak in the P port of the pump.

 **WARNING:** This has to be done in low pressure mode as it could create a dangerous fluid leak. Make sure that the pressure cannot rise (open center valve to tank, pressure relief valve unloaded).

- When oil free of air appears, tighten the connectors to the correct torque.
- The pump should prime within a few seconds. If not, please read the troubleshooting guide ([pages 55-59](#)).
- If the pump is noisy, please troubleshoot the system.
- Never operate the pump at top speed and pressure without checking the completion of pump priming.

Model Code	Chelsea Number	Displacement in <sup>3</sup> /rev	GPM (D)	Pump (D) HP	Torque (D) lb-ft	Max Pressure PSI		Speed RPM		Max Speed RPM
						Intermittent	Continuous	Min.	Max	Engine (B)
08	380418-08	1.61	9.33	19	67	4000	3500	400	2880	2015
10	380418-10	2.08	12.06	25	87	4000	3500	400	2880	2015
12	380418-12	2.26	13.10	27	94	4000	3500	400	2880	2015
14	380418-14	2.81	16.29	33	117	4000	3500	400	2880	2015
17	380418-17	3.56	20.64	42	149	4000	3500	400	2880	2015
20	380418-20	3.89	22.55	46	163	4000	3500	400	2880	2015
22	380418-22	4.29	24.87	51	179	4000	3500	400	2880	2015
25	380418-25	4.84	28.06	57	202	4000	3500	400	2880	2015

(A) GPM & Pump Input HP @ **1200 Engine RPM (1488 PTO Output RPM - 124% Ratio)** & Continuous Pressure Rating with **90% efficiency rating** considered.  
 (B) Max Engine Speed = (Max Pump Speed)/(1.24) for PTO Ratio Increase. Max Speed determined by Max PTO output speed of 2500.  
 (D) GPM & Pump Input HP @ **1200 Engine RPM (1488 PTO Output RPM - 124% Ratio)** & 2000 PSI Continuous Pressure Rating.  
 See leakage chart for additional flow losses at other pressures.

**CAUTION:** 249V Pump Options: The PTO drive gear delivers up to 250 lb-ft torque to the aftermarket PTO, and can manage the heat of 60 HP continuously. Higher horsepower can be delivered, but for shorter durations depending on the amount of power required. Ref: Ford Body Builders Manual; TorqShift® Automatic Transmission.

**NOTE:** Refer to Chelsea Owner's Manual HY25-1FRD-M1/US for complete vane pump information.

**FORMULAS:**

GPM = Cu. In. x .004329 = G/Rev x 1488 RPMs x .90 efficiency  
 HP = (GPM x Max PSI)/1714  
 Torque = (HP x 5252)/1488 RPMs

 **This symbol warns of possible personal injury.**

**249V Series Vane Pump Information**

**Start-Up Instructions (249V Series Only) (Cont'd)**

**Hydraulic Fluid Recommendations**

**Minimum Inlet Pressure**

Please read the charts in the sales leaflets as the minimum requested inlet pressure varies versus the displacement and the speed. Never go under 0.8 Bar Absolute (-0.2 Bar relative) 11.6 PSI Absolute (-2.9 PSI G).

**Maximum Inlet Pressure**

It is recommended to always have at least 1.5 Bar (22 PSI) differential between inlet and outlet. Standard shaft seals are limited to 0.7 Bar (10 PSI G) but some allow 7 Bar (100 PSI G).

**Minimum Allowable Inlet Pressure (PSI Absolute)**

Cartridge Size	Pump Speed RPM						
	1200	1500	1800	2100	2200	2300	2500
08	11.6	11.6	11.6	11.6	11.6	12.3	13.7
10	11.6	11.6	11.6	11.6	11.6	12.3	13.7
12	11.6	11.6	11.6	11.6	11.6	12.3	13.7
14	11.6	11.6	11.6	11.6	11.6	12.3	13.7
17	11.6	11.6	11.6	11.6	12.3	13.0	13.7
20	11.6	11.6	11.6	11.6	12.3	13.0	13.7
22	11.6	11.6	11.6	12.3	13.0	13.0	14.2
25	11.6	11.6	11.6	13.0	13.7	13.7	15.2

Inlet pressure is measured at inlet flange with petroleum base fluids at viscosity between 60 and 300 SUS. The difference between inlet pressure at the pressure at the pump flange and atmosphere pressure must not exceed 2.9 PSI to prevent aeration.

Multiply absolute pressure by 1.25 for HF-3, HF-4 fluid by 1.35 for HF-5 fluid by 1.10 for ester or rapeseed base.

**Minimum Outlet Pressure**

It is recommended to always have at least 1.5 Bar (22 PSI) differential between inlet and outlet.

**Fluids:**

**DENISON Classifications**

Types of fluids: For all types of fluids, DENISON's products have different pressures, speeds and temperature limits. Please refer to the sales leaflets for a DENISON T6C Vane Pump.

- HF-0 = Anti-wear petroleum base
- HF-1 = Non-antiwear petroleum base
- HF-2 = Antiwear petroleum base
- HF-3 = Water-in-oil invert emulsions
- HF-4 = Water glycol solutions
- HF-5 = Synthetic fluids

**Filtration Recommendations**

- NAS 1638 class 8 or better.
- ISO 18/14 or better.

Inlet strainers: DENISON does not recommend inlet strainers. If requested, a 100 mesh (149 microns) is the finest mesh recommended.

**Start-Up Instructions (249V Series Only) (Cont'd)****Hydraulic Fluid Recommendations (Cont'd)****Recommended Fluids**

Petroleum based antiwear R and O fluids. These fluids are the recommended fluids for pumps and motors. Maximum catalog ratings and performance data are based on operation with these fluids. These fluids are covered by DENISON Hydraulics HF-0 and HF-2 specifications.

For optimum performance, Chelsea recommends Parker DuraClean™ Premium Hydraulic Fluid available from Parker Hydraulic Filter Division. For more information about DuraClean, visit [www.Parker.com](http://www.Parker.com) or contact Hydraulic Filter Division by email at [HFDinsidesales@parker.com](mailto:HFDinsidesales@parker.com).

**Acceptable Alternate Fluids**

The use of fluids other than petroleum based antiwear R & O fluids requires that the maximum ratings of the pumps will be reduced. In some cases the minimum replenishment pressures must be increased.

**Viscosity**

	Mobile	Industrial
Max. (cold start, low speed & pressure)	2000 cSt - 9400 SUS	860 cSt - 3900 SUS
Max. (full speed & pressure)	108 cSt - 500 SUS	108 cSt - 500 SUS
Optimum (max. life)	30 cSt - 140 SUS	30 cSt - 140 SUS
Min. (full speed & pressure for HF-1, HF-3, HF-4 & HF-5 fluids)	18 cSt - 90 SUS	18 cSt - 90 SUS
Min. (full speed & pressure for HF-0 & HF-2 fluids)	10 cSt - 60 SUS	10 cSt - 60 SUS

**Viscosity Index**

90 minimum higher values extend the range of operating temperatures.

**Temperatures**

The usual limiting factor of temperature (low or high) comes from the obtained viscosity. The seals are sometimes the limit: standard seals range from -30°C to 90°C (-9.4°F to 194°F).

Maximum fluid temperature (Ø)	°C	°F
HF-0, HF-1, HF-2	+100	+212
HF-3, HF-4	+50	+122
HF-5	+70	+158
Biodegradable fluids (esters & rapeseed base)	+65	+149
Minimum fluid temperature (Ø) (also depend on max. viscosity)	°C	°F
HF-0, HF-1, HF-2, HF-5	-18	-0.4
HF-3, HF-4	+10	+50
Biodegradable fluids (esters & rapeseed base)	-20	-4
Over or under these values, please contact DENISON		

**Water Contamination in the Fluid**

Maximum acceptable content of water:

- 0.10% for mineral base fluids.
- 0.05% for synthetic fluids, crankcase oils, biodegradable fluids.

If the amount of water is higher, then it should be drained off the circuit.

249V Series Vane Pump Information

Start-Up Instructions (249V Series Only) (Cont'd)

Pump & Cartridge Breakdown Drawing

Torque to 80-85 lb-ft  
[108-115 N-m]

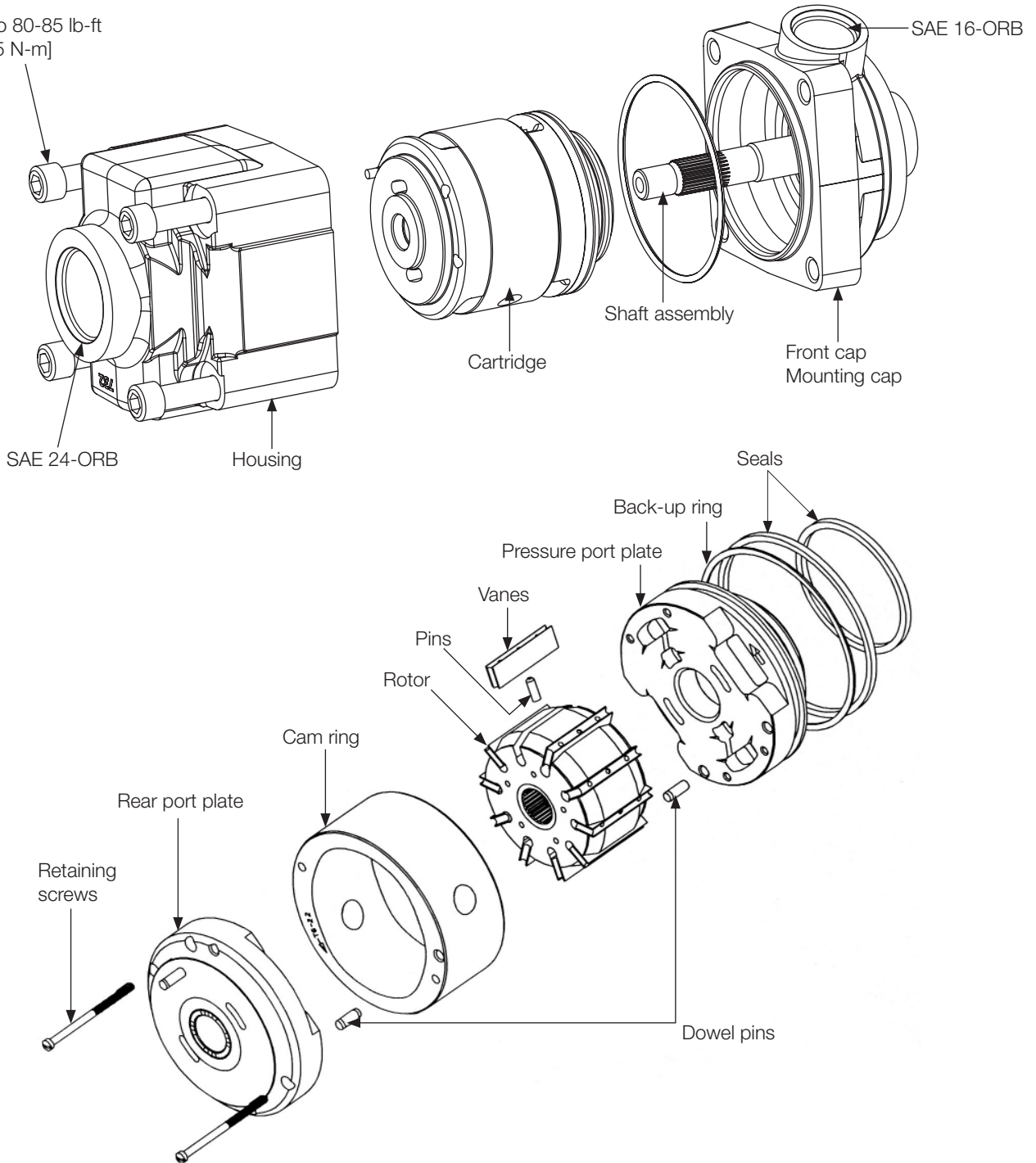

**! WARNING:** The purpose of the two screws is just to hold the cartridge together. When tightening them, check the rotation of the rotor and vane assembly.

**! This symbol warns of possible personal injury.**

**Start-Up Instructions (249V Series Only) (Cont'd)**

**Pump Cartridge Replacement**

**Removal**

1. Lay the PTO/Pump on the table (**Fig. 40**).

**NOTE:** PTO must be supported on table.



Figure 40

2. Unscrew the 4-Bolts (**Fig. 41**).

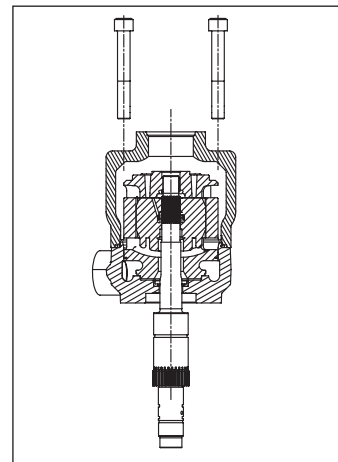

Figure 41

3. Remove the housing (**Fig. 42**).

**! WARNING:** This seal can sometimes stay in the housing.

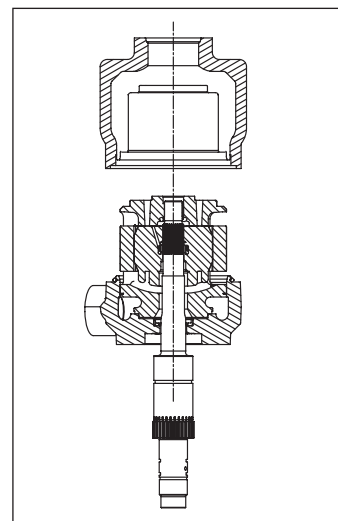

Figure 42

**! This symbol warns of possible personal injury.**

**Start-Up Instructions (249V Series Only) (Cont'd)**

**Pump Cartridge Replacement (Cont'd)**

4. Disassemble the cartridge/front cap with an extractor (Fig. 43).

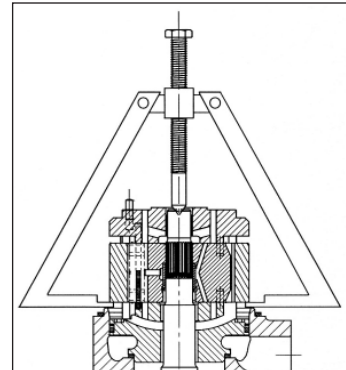

Figure 43

5. Remove cartridge from shaft (Fig. 44).

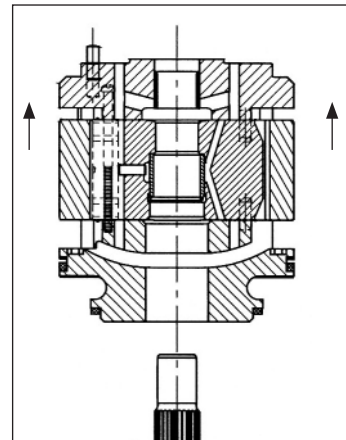

Figure 44

**! WARNING:** If you want to reassemble a new cartridge (Fig. 45).

**Installation**

6. Fit the cartridge into the housing (Fig. 45).

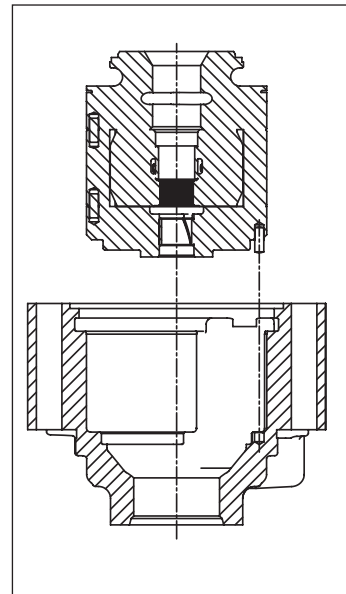

Figure 45

**! This symbol warns of possible personal injury.**

**Start-Up Instructions (249V Series Only) (Cont'd)**

**Pump Cartridge Replacement (Cont'd)**

7. Check if the dowel pin is in its position in the housing by trying to rotate the cartridge (Fig. 46).

**WARNING:** Put some grease on the seals to prevent them from moving. If the cartridge does rotate, the dowel pin is not in the hole. Take the cartridge out and try again.

If the cartridge does not fit in the housing correctly, check the concentricity of the three elements = port plates (rear and pressure) and cam ring.

**WARNING:** Never use a hammer. The cartridge is to fit into the housing without any tools (Fig. 47).

8. Assemble the front cap ASSY on the housing and cartridge ASSY (Fig. 48).

**WARNING:** Position the shaft/front cap ASSY only if the cartridge is well positioned, dowel pin in the housing dowel pin hole. Put some grease on the seals to prevent them from moving.

9. Final ASSY (Fig. 49).

- a. Always check if the shaft rotates freely. If not, disassemble and go back to the previous step.
- b. Flip/rotate the pump to fit the 4 screws.
- c. Fix the pump to the PTO before tightening the pump's bolts.
- d. Check the porting configuration.
- e. Tighten the 4-Bolts. Step by step to avoid damaging the seals (Fig. 50).
- f. Always check if the shaft rotates freely. If not, disassemble and go back to the previous step.

**Torque Requirements:**

80-85 lb-ft	[108-115 N-m]
-------------	---------------

**WARNING:** This symbol warns of possible personal injury.

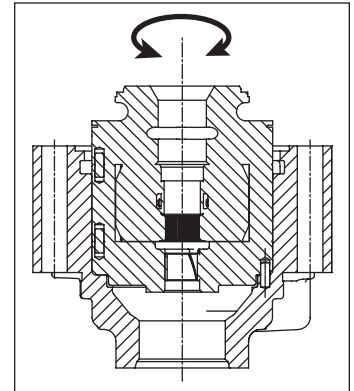

Figure 46

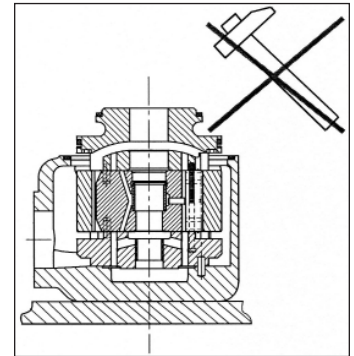

Figure 47

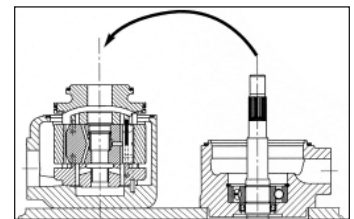

Figure 48

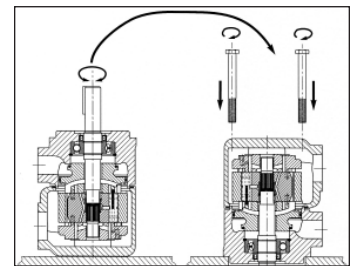

Figure 49

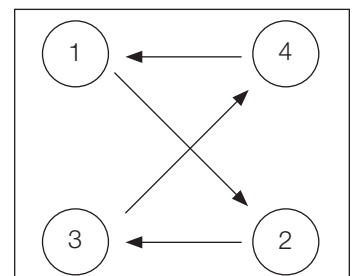

Figure 50

---

**Vane Pump Troubleshooting Guide**

1. No flow, no pressure
  - a. Is the pump rotating?
    - a-1. Check if the coupling is rotating. If not, check the rotation of the electric motor.
    - a-2. Check the keys of the pump and E motor shaft.
    - a-3. Check if the shaft is not broken.
  - b. Is the rotation in the correct direction?
    - b-1. Check if the rotation of the pump corresponds to the arrow on the name plate.
    - b-2. Check if the wiring of the electric motor is correct.
  - c. Is the air bleed-off done?
    - c-1. Check that no air is still located in the pressure line. Loosen a connector.
  - d. How are the inlet conditions?
    - d-1. Check if the inlet gate valve is not closed.
    - d-2. Check the oil level.
    - d-3. Check if the inlet hose in the tank is under the oil tank level.
    - d-4. Check if an air intake is not disturbing the inlet (missing inlet flange seal, air trapped in suction line as examples).
    - d-5. Check if the pump is not located too high above the oil level.
    - d-6. Check if the tank is not completely sealed. Then the lack of atmospheric pressure will not allow the pump to prime.
    - d-7. Check if all connections and seals are airtight.
  - e. Is the Viscosity not too high?
    - e-1. Check if the oil characteristics are not incompatible with the temperature and the pump's requirements. Too high Viscosity will "stick" the vane fluid and enable the pump to suck the oil correctly.
  - f. Is the pump flow not going somewhere else?
    - f-1. Check the hydraulic circuit and the main sequences. Doing so, you will check if all the valves are set or work properly.
    - f-2. Check if the main relief valve is not set at an extremely low pressure and therefore bringing all the flow back to the tank.
    - f-3. Check if in the directional valves the spools are not sticking in a position that brings the flow back to the tank.
    - f-4. Check if the check valve is not mounted "upside down".
  - g. Is the receptor working correctly?
    - g-1. Check if the motor does not let all the flow leak internally.
    - g-2. Check if the cylinder inner seals are not ruined.
  - h. Is the speed high enough?
    - h-1. Check if the minimum speed is reached. Mobile pumps require 400 RPM and industrial pumps require 600 RPM.

---

**Vane Pump Troubleshooting Guide (Cont'd)**

2. Not enough flow (or not the flow required)
  - a. Are the components OK?
    - a-1. Check the displacement of the pump.
    - a-2. Check if the speed of the pump is not too low or too high (E motor or thermic engine sized too small so dropping the speed too low).
    - a-3. Check if the main relief valve is not set at an extremely low pressure and therefore venting some flow back to the tank.
    - a-4. Check if in the directional valves the spools are not sticking in a position that brings part of the flow back to the tank.
    - a-5. Check if the hydraulic motor is not leaking internally due to a bad efficiency, low viscosity.
    - a-6. Check if the cylinder inner seals are not ruined and therefore allow internal leakage.
  - b. Is the connection from the tank to the pump correct?
    - b-1. Check if there is no air intake between the pump and the inlet pipe (bad seals for example).
    - b-2. Check if the inlet hose is convenient for the required velocity ( $0.5 < V < 1.9$  m/s).
    - b-3. Check if the pump is not too high compared to the oil level or if the pump is not too far from the tank (check the inlet absolute pressure with the catalog values).
    - b-4. Check if the gate valve is not semi-open.
    - b-5. Check if the inlet strainer is sized correctly (250 m mesh mini) or not clogged.
  - c. Is the tank design correct?
    - c-1. Check if the oil level is correct.
    - c-2. Check if the suction pipe is under the oil level during the complete cycle of the machine.
    - c-3. Check if the inlet hose fitted in the tank is cut with an angle wider than 45-degree.
    - c-4. Check if this inlet hose is not too close to the tank wall or to the bottom of the tank and therefore limits the "vane flow".
    - c-5. Check if the suction hose is not located near the return line and therefore sucking a lot of air coming from these turbulences.
    - c-6. Check if baffles are required to allow correct aeration of the fluid.
    - c-7. Check if the air filter is not clogged or undersized (not well dimensioned).
    - c-8. Check if the tank is not fully tight, not allowing the atmospheric pressure to apply.
  - d. Is the oil convenient?
    - d-1. Check if the oil characteristics are not incompatible with the pump's requirements.
    - d-2. Check if the viscosity is not too high, therefore "sticking" some vanes in the rotor or blocking the vane fluid.
    - d-3. Check if the high temperature does not destroy the viscosity of the fluid. Doing so, the internal leakage will "consume" the flow.

---

**Vane Troubleshooting Guide (Cont'd)**

3. No pressure
  - a. Is the hydraulic circuit correctly designed?
    - a-1. Check the hydraulic circuit schematic.
  
  - b. Is the circuit correctly piped?
    - b-1. Compare the schematic to the piped circuit.
  
  - c. Are the components working properly?
    - c-1. Check the main sequences. Doing so, you will check if all the valves are set or work properly.
    - c-2. Check if the main relief valve is not set at an extremely low pressure and therefore bringing all the flow back to the tank.
    - c-3. Check if in the directional valves the spools are not sticking in a position that brings the flow back to the tank.
  
4. Not enough pressure
  - a. Check as when "no pressure" 3.
  
  - b. Is the system well dimensioned?
    - b-1. Check if the flow required is not over the available flow and therefore cannot build-up pressure.
  
  - c. Is there an internal leakage somewhere that maintains a certain pressure?
    - c-1. Check all the possible faulty components, from the pump to all the receptors and intermediates (high pressure seals, mechanical wear).
  
5. Uncommon noise level
  - a. Is the noise coming from the pump?
    - a-1. Check the mechanical link of the pump shaft: alignment, balancing of the coupling or Universal joint, key properly fastened.
    - a-2. Check if the air bleed has been done correctly.
    - a-3. Check if there is no air intake from the tank to the pump (nor through the shaft seal).
    - a-4. Check if the hose strain force does not create this noise.
    - a-5. Check if the oil level is correct.
    - a-6. Check if the oil in the tank is not aerated.
    - a-7. Check if the strainer is not clogged or under-dimensioned.
    - a-8. Check if the inlet pipe is under the oil level.
    - a-9. Check if the air filter is not clogged or too small.
    - a-10. Check if the speed is not incompatible with the catalog values.
    - a-11. Check if the oil is compatible with the catalog recommendations.
    - a-12. Check if the inlet pressure is not higher than the outlet pressure.
  
  - b. Is the noise coming from the surroundings?
    - b-1. Check the hoses and see if the noise is not coming back to the pump this way.
    - b-2. Check the pressure piping and see if its length dumps or amplifies the noise.
    - b-3. Check if the structure of the tank is stiff enough to avoid amplification/resonance.
    - b-4. Check the E motor fan.
    - b-5. Check the balancing of the E motor.
    - b-6. Check the water cooler and its theoretical limits.
    - b-7. Check the filtration unit, its capacity and if the noise does not come from the opened by-pass valve.

---

**Vane Troubleshooting Guide (Cont'd)**

6. Unusual heat level
  - a. Does the heat appear when the pump is running without pressure?
    - a-1. Check the oil level and the suction pipe. Is the oil coming to the pump (check the length of the pipe, its internal diameter, all that could influence the inlet pressure)?
    - a-2. Check if the air bleed has been done correctly.
    - a-3. Check if the flow versus the volume of oil in the tank is correct to obtain a good cooling effect.
    - a-4. Check if a cooler is required or, if there is one, if it is well dimensioned.
    - a-5. If there is a cooler, check if it is working (example for water cooler: is the water flow open or sufficient).
    - a-6. Check if the hydraulic circuit is not bringing back the flow directly to the inlet port. Doing so, it would create a very small closed circuit not able to cool down the fluid.
    - a-7. Check the quality of the fluid.
    - a-8. Check the velocity of the fluid.
    - a-9. Check the filtration unit, its capacity and if the heat does not come from the open by-pass valve or if it is under-dimensioned (bigger delta P).
  - b. Does the heat appear when the pump is running with pressure?
    - b-1. Check the viscosity.
    - b-2. Check the pressure rating.
    - b-3. Check if the cooler is working correctly or well dimensioned.
    - b-4. Check if the relief valve is not creating this heat because always open.
    - b-5. Check if any other component in the system is not creating this heat due to an internal defect.
    - b-6. Check if there is a big temperature differential between the inlet and the outlet.
7. Shaft seal leakage
  - a. Is the seal destroyed?
    - a-1. Check the alignment and the correct power transmission (non-homokinetic movement, high radial force as examples).
    - a-2. Check the inlet pressure and compare it to the catalog values.
    - a-3. Check if the bad suction conditions do not create a vacuum that could even reverse the seal lip.
    - a-4. Check if the external environment is not too dirty and therefore ruining the seal.
  - b. Is the seal only leaking?
    - b-1. Check the alignment of the front shaft and check if there is not any radial load.
    - b-2. Check if seal lip has not been cut during a maintenance operation.
    - b-3. Check if the inlet pressure is not over or under the catalog values. This has to be done for the whole cycle because the inlet pressure can vary from time to time.
    - b-4. Check if the seal material has not been modified because of a too warm environment. The seal can vulcanize and stop sealing correctly.
    - b-5. Check the acidity of the oil that can "burn" the seals material. It will therefore destroy the elasticity of the sealing.
    - b-6. Check if the chosen seal (high pressure seal for example) is not too stiff for the use. If the environment requires some elasticity due to a gentle misalignment, a high pressure seal will not be able to follow the movement and therefore leak.



# 272-FORD

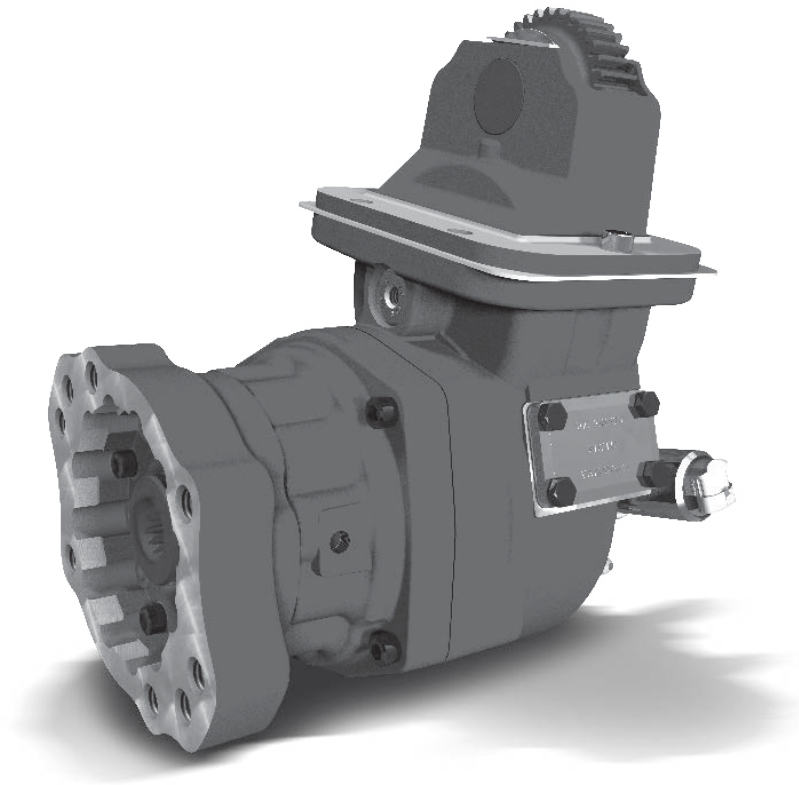

## FORD TorqShift® 6R140 Transmission

**Medium Duty F-650/F-750  
6.7L Diesel MY2016-MY2025  
6.8L Gas MY2016-MY2019  
7.3L Gas MY2020-MY2025**

## Mounting the PTO

1. Remove the PTO aperture cover plate (**Fig. 51**).
2. Ensure aperture surface is clean (**Fig. 52**). Discard cover plate. **DO NOT** discard the gasket. It will be used when installing the adapter on the transmission (**Fig. 52**).

**IMPORTANT:** Inspect the gasket for rips, tears, and deformities that may cause leaks. If there are any questions about the integrity of the gasket, replace with a new gasket. If the gasket needs to be replaced, order Chelsea PN 22-P-124. **DO NOT** use any other gasket material than that supplied by Ford or Chelsea specific for the 6R140 transmission.

3. Install the studs (**Fig. 53**) hand tight in the PTO aperture pad using a stud driver. **DO NOT** use air tools to install studs.

**CAUTION:** Over tightening of the studs or running the shoulder past the transmission mounting surface may damage stud and/or transmission threads (**Fig. 54**).

**NOTE: DO NOT** use gasket maker or sealant with automatic transmissions. Always check to be sure that the studs do not interfere with transmission gears.

4. Slide the gasket supplied with the transmission over the dowels on to the geared adapter.
5. Install the geared adapter into the transmission aperture over the studs (**Fig. 55**).
6. Install the gasket supplied with the PTO over the studs and against the geared adapter (**Fig. 55a**).

**WARNING:** Ensure all fasteners and fittings are torqued according to their manufacturer's specification.

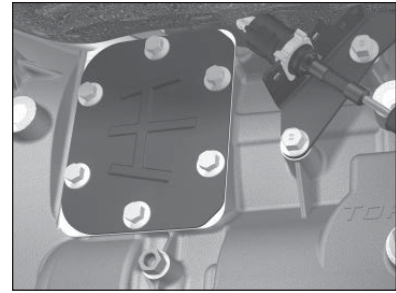

Figure 51

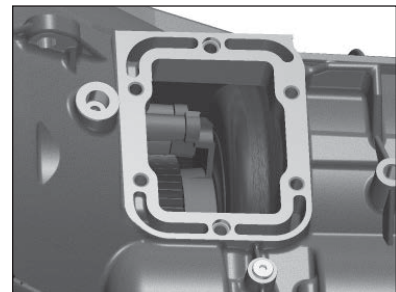

Figure 52

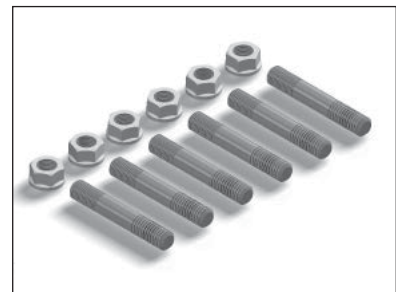

Figure 53

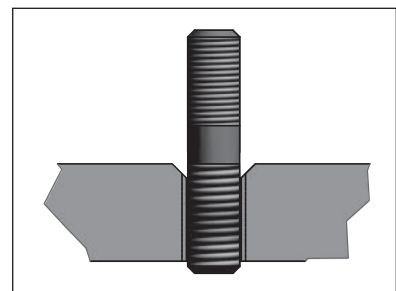

Figure 54

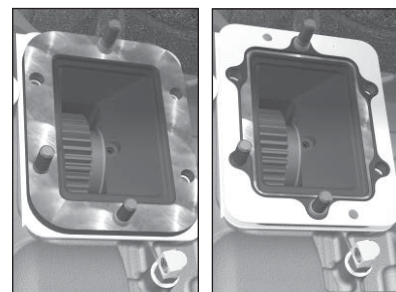

Figure 55

Figure 55a

**Mounting the PTO (Cont'd)**

- 7. Install the PTO over the studs and secure the PTO with the self-locking nuts provided with the PTO (Fig. 56).

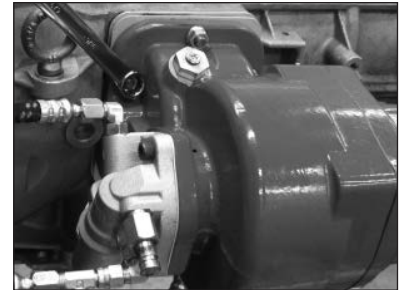

Figure 56

**NOTE:** Self-locking nuts **DO NOT** require lock washers (Fig. 57).

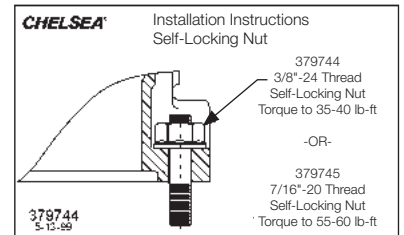

Figure 57

- 8. Torque the self-locking nuts in a crossing pattern to their proper specifications (Fig. 58).

**TORQUE SPECS:**

Self-Locking Nuts - 35-40 lb-ft [47-54 N-m]



Figure 58

**Hose Assembly Identification**

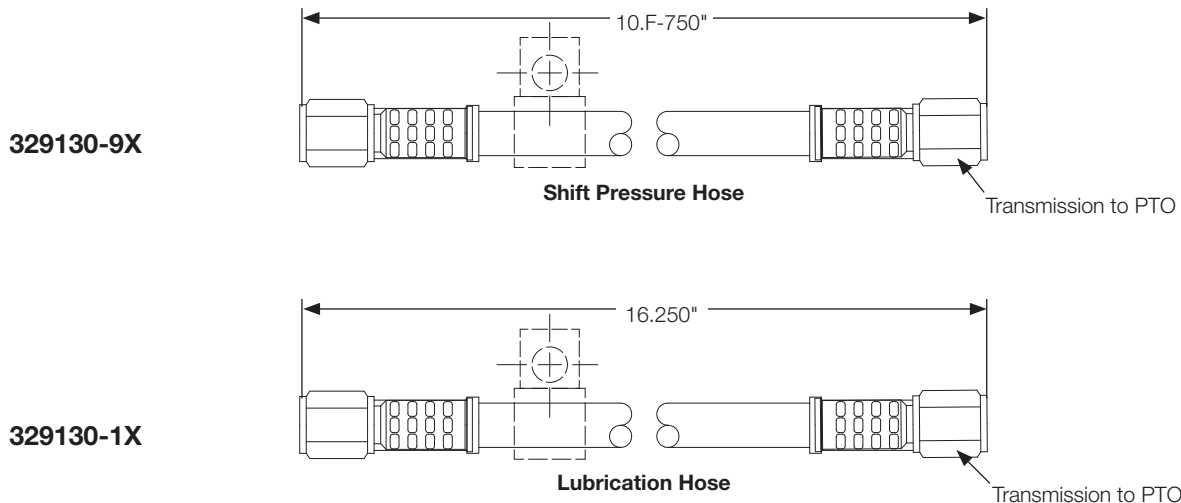

**Wiring Installation (Shift Option B)**  
**Medium Duty F-650/F-750 – MY2016-MY2025 – 6.7L Diesel**  
**Medium Duty F-650/F-750 – MY2016-MY2019 – 6.8L Gas**  
**Medium Duty F-650/F-750 – MY2020-MY2025 – 7.3L Gas**  
**272F & 272H w/o Electronic Overspeed Control (EOC)**

(SK-611 Rev B)

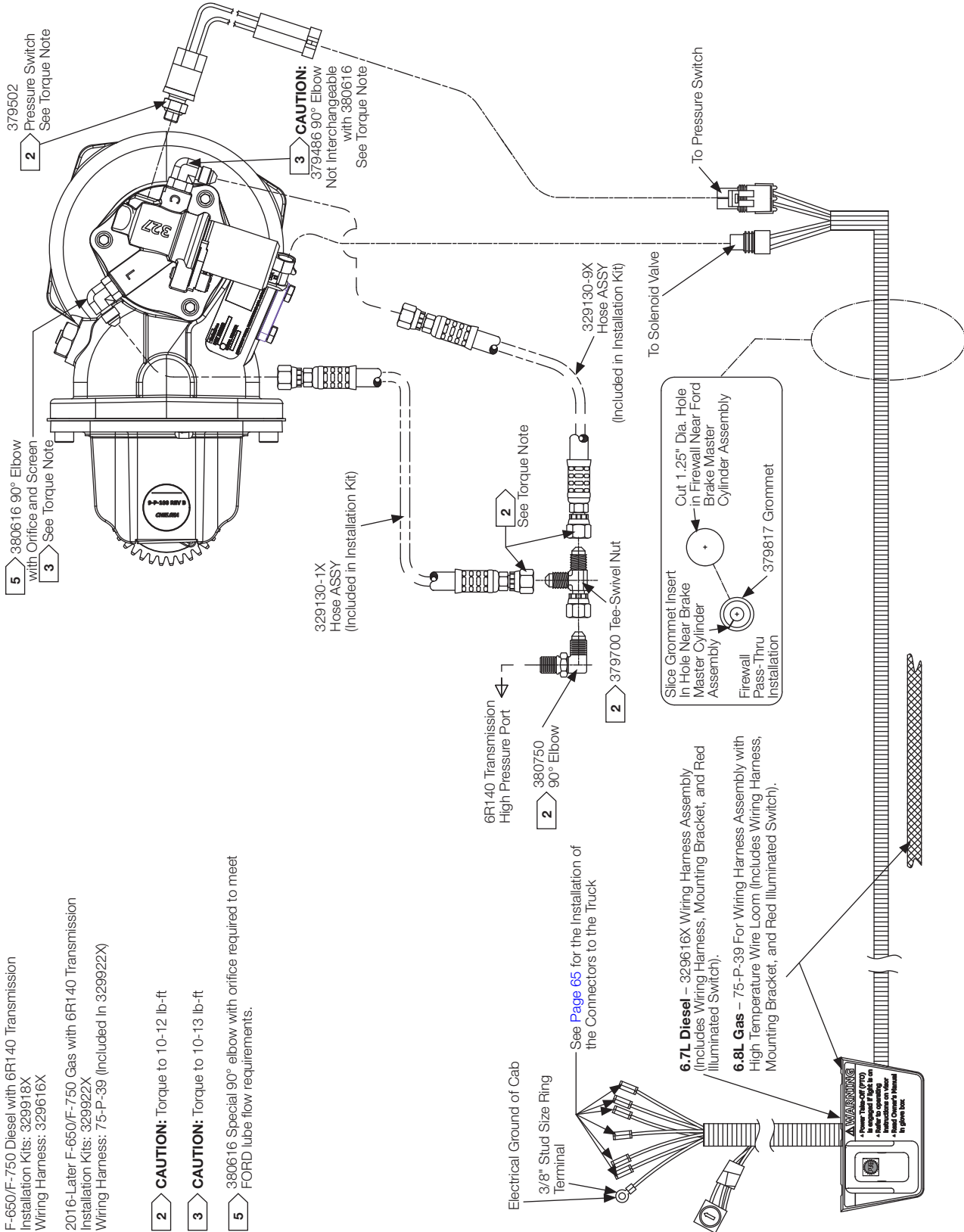

F-650/F-750 Diesel with 6R140 Transmission Installation Kits: 329918X Wiring Harness: 329616X  
 2016-Later F-650/F-750 Gas with 6R140 Transmission Installation Kits: 329922X Wiring Harness: 75-P-39 (Included In 329922X)

- 2 **CAUTION:** Torque to 10-12 lb-ft
- 3 **CAUTION:** Torque to 10-13 lb-ft
- 5 380616 Special 90° elbow with orifice required to meet FORD lube flow requirements.

See Page 65 for the Installation of the Connectors to the Truck

**6.7L Diesel** – 329616X Wiring Harness Assembly (Includes Wiring Harness, Mounting Bracket, and Red Illuminated Switch).

**6.8L Gas** – 75-P-39 For Wiring Harness Assembly with High Temperature Wire Loom (Includes Wiring Harness, Mounting Bracket, and Red Illuminated Switch).



**NOTE:** Strip wire ends 0.25" Prior to installing connector.

**Wiring Installation Chart (Shift Option B)**

(SK-611 Rev B)

**Medium Duty F-650/F-750 – MY2016-MY2025 – 6.7L Diesel  
272F w/o Electronic Overspeed Control (EOC)**

Medium Duty F-650/F-750 – DIESEL							
Chelsea PTO Wire Color		Blunt cut wires found on Driver Side behind Data Link					
		Stationary Mode			Mobile Mode		
		Function	Ford Wire Color	Circuit	Function	Ford Wire Color	Circuit
329616X Wiring Harness	Purple	12VDC Power	2016-2019 - Yellow/Grey 2020-2025 - Grey	#CBB35 #CBK03	12VDC Power	2016-2019 - Yellow/Grey 2020-2025 - Grey	#CBB35 #CBK03
	Yellow	PTO REQ1	Yellow/Green	#CE912	PTO REQ1	NOT USED	
	Yellow	PTO REQ2	NOT USED	#CE912	PTO REQ2	2016 - Blue/Orange <sup>(3)</sup> 2017-2019 - Blue/Red 2020-2021 - Blue/Green 2025 - Blue/Orange	#CE933
	White	PTO VREF	White/Brown	#LE434	PTO VREF	White/Brown	#LE434
	Green	PTO RPM	Green	#CE914	PTO RPM	Green	#CE914
	Grey	PTO RTN	Grey/Violet	#RE327	PTO RTN	Grey/Violet	#RE327
	Blue/White	PTO RELAY	2016-2019 - Blue/White 2020-2025 - Blue/Grey	#CE326	PTO RELAY	2016-2019 - Blue/White 2020-2021 - Blue/Grey 2025 - Blue/White	#CE326

NOTE: <sup>(3)</sup> Blue w/ orange prior to March 2016. Blue/Red after March 2016.

**Medium Duty F-650/F-750 – MY2016-MY2019 – 6.8L Gas**

(SK-611 Rev B)

**Medium Duty F-650/F-750 – MY2020-MY2025 – 7.3L Gas  
272H w/o Electronic Overspeed Control (EOC)**

Medium Duty F-650/F-750 – GAS							
Chelsea PTO Wire Color		Blunt cut wires found Driver Side behind Data Link					
		Stationary Mode			Mobile <sup>(1)</sup>		
		Function	Ford Wire Color	Circuit	Function	Ford Wire Color	Circuit
75-P-39 Wiring Harness	Yellow/Grey	12VDC Power	2016-2019 - Yellow/Grey 2020-2025 - Grey	#CBB35 #CBK03	12VDC Power	2016-2019 - Yellow/Grey 2020-2025 - Grey	#CBB35 #CBK03
	Yellow/Blue	PTO REQ1	2016-2019 - Yellow/Blue 2020-2025 - Yellow/Green	#CE912	PTO REQ1	NOT USED	
	Blue	PTO REQ2	2016 - Blue/Orange or Red <sup>(2)</sup> 2017-2018 - NOT USED	#CE933	PTO REQ2	2016 - N/A 2017-2019 - Blue/Red 2020-2025 - Blue/Orange	#CE933
	Yellow/Green	PTO VREF	Yellow/Green	#LE424	PTO VREF	Yellow/Green	#LE424
	Green	PTO RPM	Green	#CE914	PTO RPM	Green	#CE914
	Yellow/Violet	PTO RTN	Yellow/Violet	#RE407	PTO RTN	Yellow/Violet	#RE407
	Blue/White	PTO RELAY	Blue/White	#CE326	PTO RELAY	Blue/White	#CE326

NOTE: <sup>(1)</sup> Mobile Mode is not available on the 2016 Gas Trucks., <sup>(2)</sup> Blue/Orange prior to March 2016. Blue/Red after March 2016.

See Appendix for more year specific wiring information.

NOTE: Some early build 2016 6.8L gas F-650/F-750 vehicles have 2 identically colored wires for PTO, which are located in the blunt cut harness under the driver side dash. They are Yellow/Green stripes. Use a voltmeter to identify which circuit you need:

- One wire has 0VDC to ground (PCM PIN C1551B-84 Circuit #CE912)
- One has +5VDC to ground (PTO VREF, PCM PIN 01551B-52 Circuit #LE424)
- Circuit #CE912 will be changing to Yellow/Blue in later production.

NOTE: Early build 2016 6.8L gas F-650/F-750 vehicles (built before 10/22/15) have an incorrectly pinned customer access circuit. Circuit #CE326 is pinned in PCM connector C175B PIN 96. This circuit should be located at PIN 98. Vehicles built after 10/22/15 will have this circuit in the correct PCM connector cavity.

Reference Ford SVE Bulletin Q-241 for more information.

**Mobile to Stationary Switch**

1. If required for your application a Single Pole Double Throw (SPDT) switch can be installed in the cab to control PTO function between Mobile Mode and SEIC Stationary Mode. Connect the Chelsea YELLOW wire as illustrated below.

**Switching Between Stationary and Mobile**

**To switch between Mobile & Stationary Mode – Install a Single Pole Double Throw (SPDT) switch as shown:**

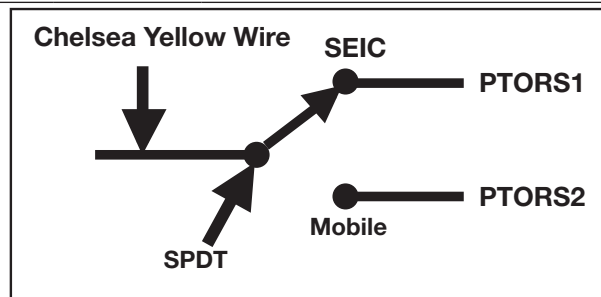



**Wiring Installation Chart (Shift Option K)****(SK-612)****Medium Duty F-650/F-750 – MY2016-MY2025 – 6.7L Diesel  
272F w/ Electronic Overspeed Control (EOC)**

	Chelsea PTO Wire Harness	Stationary Mode			Mobile Mode		
		Function	Ford Wire Color	Circuit	Function	Ford Wire Color	Circuit
<b>329617X Wiring Harness</b>	White	PTO REF	White/Brown	#LE434	PTO REF	White/Brown	#LE434
	Grey	PTO RTN	Grey/Violet	#RE327	PTO RTN	Grey/Violet	#RE327
	Green	PTO RPM	Green	#CE914	PTO RPM	Green	#CE914
	Blue/White	PTO RLY	2016-2019 - Blue/White 2020-2025 - Blue/Grey	#CE326	PTO RLY	2016-2019 - Blue/White 2020-2021 - Blue/Grey 2025 - Blue/White	#CE326
	Black w/ Ring Terminal	Chassis Ground			Chassis Ground		
	Yellow	PTO REQ1	Yellow/Green	#CE912	PTO REQ2	2016 - Blue/Orange <sup>(*)</sup> 2017-2019 - Blue/Red 2020-2021 - Blue/Green 2025 - Blue/Orange	#CE933
	Blue	Chelsea EOC Blue Wire			Chelsea EOC Blue Wire		
	Red	Chelsea EOC Green Wire			Chelsea EOC Green Wire		

**NOTE:** EOC not available for MY2016 & Prior., <sup>(\*)</sup> Blue w/ Orange prior to March 2016. Blue/Red after March 2016. Refer to Ford Body Builders web site for more on this subject.

**Wiring Installation Chart (Shift Option K)****(SK-612)****Medium Duty F-650/F-750 – MY2017-MY2019 – 6.8L Gas  
Medium Duty F-650/F-750 – MY2020-MY2025 – 7.3L Gas  
272H w/ Electronic Overspeed Control (EOC)**

	Chelsea PTO Wire Harness	Stationary Mode			Mobile Mode		
		Function	Ford Wire Color	Circuit	Function	Ford Wire Color	Circuit
<b>329617X Wiring Harness</b>	White	PTO REF	Yellow/Green	#LE424	PTO REF	Yellow/Green	#LE424
	Grey	PTO RTN	Yellow/Violet	#RE407	PTO RTN	Yellow/Violet	#RE407
	Green	PTO RPM	Green	#CE914	PTO RPM	Green	#CE914
	Blue/White	PTO RLY	Blue/White	#CE326	PTO RLY	Blue/White	#CE326
	Black w/ Ring Terminal	Chassis Ground			Chassis Ground		
	Yellow	PTO REQ1	2016-2019 - Yellow/Blue 2020-2025 - Yellow/Green	#CE912	PTO REQ2	2016 - N/A 2017-2019 - Blue/Red 2020-2025 - Blue/Orange	#CE933
	Blue	Chelsea EOC Blue Wire			Chelsea EOC Blue Wire		
	Red	Chelsea EOC Green Wire			Chelsea EOC Green Wire		

**NOTE:** EOC not available for MY2016 & Prior. Refer to Ford Body Builders web site for more on this subject.

12VDC Power	Stationary Mode or Mobile Mode	
Chelsea EOC Wire	F-650/F-750	Circuit
Red Wire	2016-2019 - Yellow/Grey 2020-2025 - Grey	#CBB35 #CBK03
Black w/ Ring Terminal	Chassis Ground	

**Wiring Installation (Shift Option B)  
Medium Duty F-650 – MY2012-MY2015 – 6.8L Gas  
272J w/o Electronic Overspeed Control (EOC)**

**(SK-613 Rev A)**

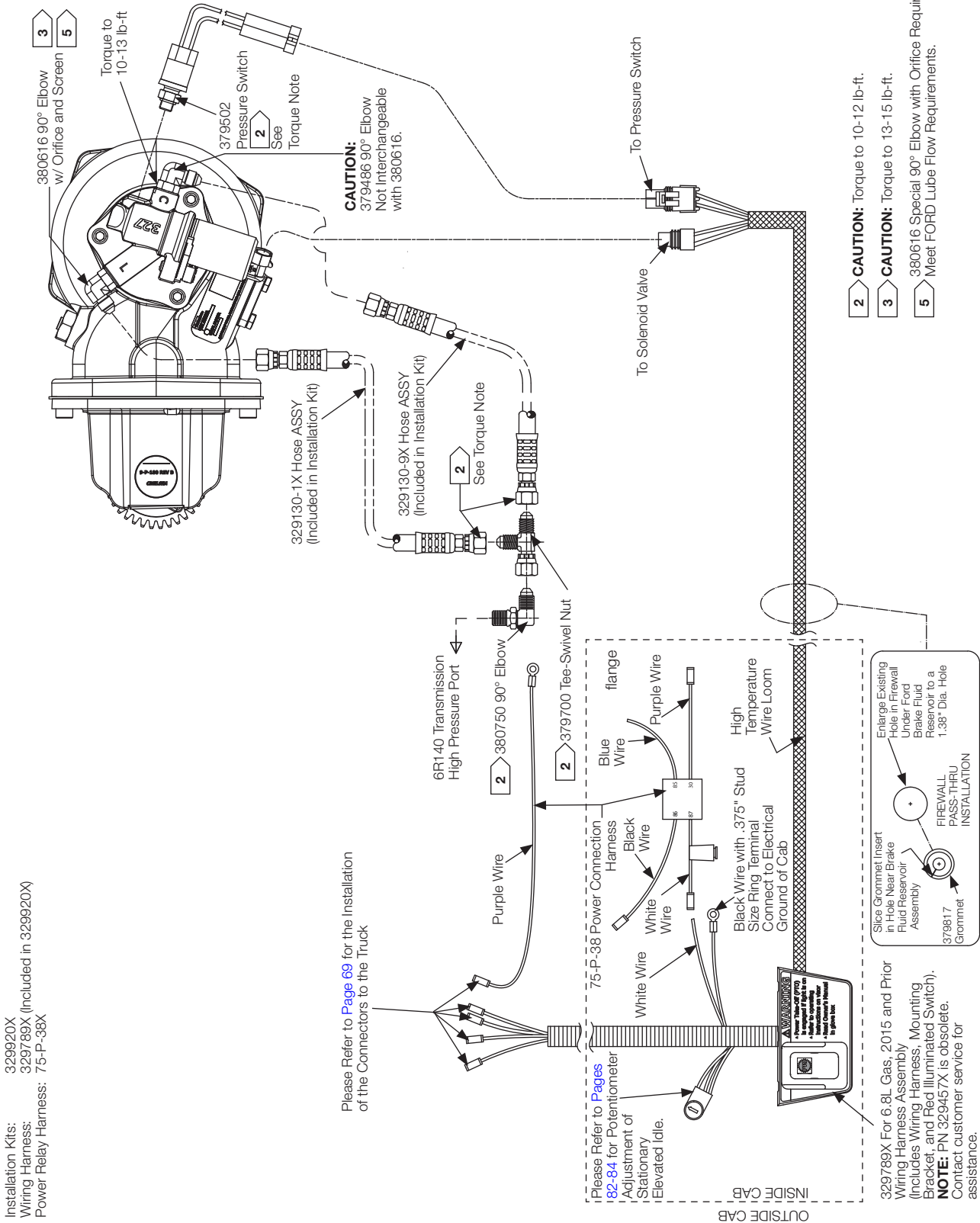

**Wiring Installation Chart (Shift Option B)  
Medium Duty F-650 – MY2012-MY2015 – 6.8L Gas  
272J w/o Electronic Overspeed Control (EOC)**

(SK-613 Rev A)

**Wiring Interface Configurations**

Chelsea PTO Wire Harness		Stationary Mode (Mobile Mode Not Available)		
		Function	Ford Wire Color	Circuit
<b>75-P-38 Power Connection Harness</b>	<b>Under Hood</b>			
	Purple w/ Butt Connector (80")		Violet/Yellow	#870
	Purple w/ Ring Terminal (80")		Battery Junction Box Battery Connection Post	
	<b>Under Dash</b>			
	Black		Ford Ground Circuit Black	#57
	Blue		12VDC Blue/Green	
	Purple		Violet/Yellow	#870
White		Chelsea White Wire on 329789X Main Harness		
<b>329789X Main Harness</b>	<b>Under Hood</b>			
	Green	PTO RPM	Ford Circuit (Green)	#CE914
	Blue/White	PTO RLY	Ford Circuit (Blue/White)	#CE326
	Blue	PTO REQ2	Blue/Orange or Blue/Red (effective March 2016)	#CE933
	Yellow	PTO REQ1	Yellow/Green	#CE912
	<b>Under Dash</b>			
	Black w/ Ring Terminal		Chassis Ground	
See Appendix for more year specific wiring information.				



# 247 Series

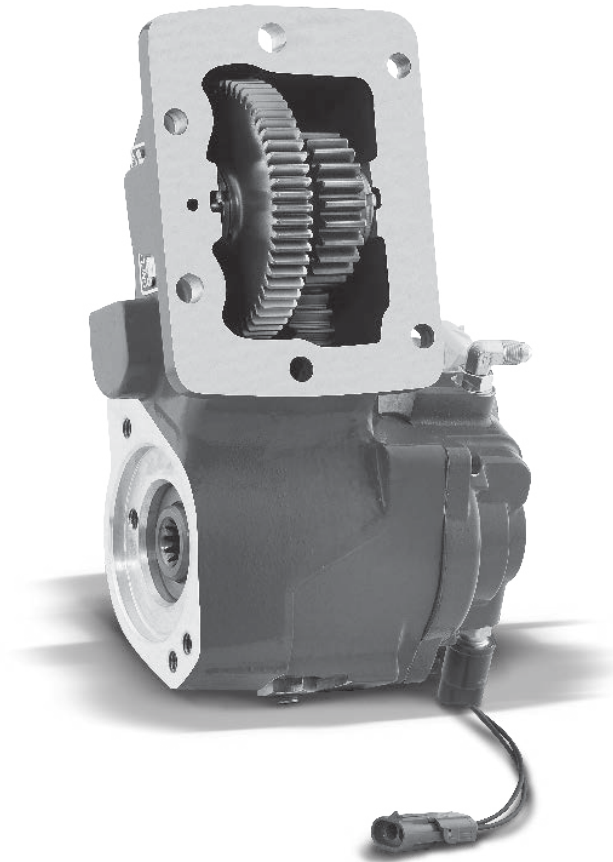

## **FORD TorqShift® 5R110 Transmission**

**Super Duty F-250-F-550  
6.7L Diesel MY2009-MY2010  
6.8L Gas MY2009-MY2016**

## 247 Series Installation Instructions

### In-Cab PTO Switch Installation

**NOTE:** Before starting installation of the electrical wiring:

1. Disconnect the battery cables from the battery and secure to prevent accidental contact.
2. Locate a position in the cab for mounting the PTO switch and mounting bracket. The shaded area in (Fig. 59) shows the Occupant Protection Zone of the deployed air bags that are available in these vehicles.

**WARNING:** To avoid personal injury or equipment damage: Do not install any item from a Chelsea Power Take-Off (i.e.: PTO switch or mounting bracket) in the Occupant Protection Zone.

**CAUTION:** Before drilling any holes, make sure there is adequate clearance on both sides.

For electrical installation, see installation sketch on [page 78](#) for non-EOC and [page 80](#) for EOC.

1. Locate suitable location to install PTO switch.
2. Locate and remove the customer access panel located on the lower left portion of the instrument panel (driver's side) (Fig. 60).
3. After determining the location of the PTO switch, run wiring assembly over to the area under the vehicle steering column. You are now ready to attach the wires from the Chelsea wiring harness.

**NOTE:** Wiring Strategy is slightly different between the Gas and Diesel engines. Use the charts listed on [pages 79 and 81](#) for complete wiring chart information for prior years when using Chelsea wiring harness.

4. Located in the cabin, tagged and bundled above the parking brake assembly (Fig. 61), are the wires needed to connect the Chelsea PTO wiring harness to the Ford SEIC strategy. Wires that will be connected at this bundle from the Chelsea wiring harness are the Black, Orange, Yellow, White and Red wires. All have butt connector ends. Connect these wires using Wiring Charts [page 79 or 81](#) of this manual.

**WARNING:** Ensure all fasteners and fittings are torqued according to their manufacturer's specification.

**!** This symbol warns of possible personal injury.

Consult Ford Body Builder SVE Q-236R3

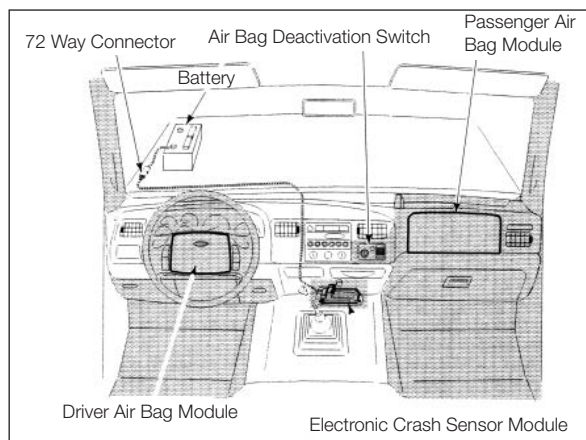

Figure 59

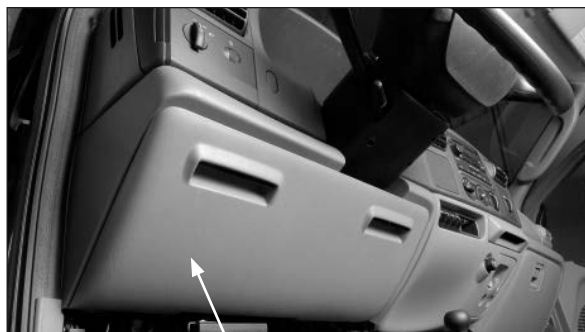

Figure 60

Customer Access Panel



Figure 61



Figure 62

**In-Cab PTO Switch Installation (Cont'd)**

- Locate Ford circuit #294 (White w/ Light Blue) or for MY2008 circuit #CBP44 (purple). This wire can be found under-dash on the right side of the customer access and is blunt cut. Connect Chelsea wire White w/ Light Blue stripe using a butt connector to this Ford wire. Next, connect the black ground wire with a ring terminal to one of the screws located on the right side of the access area dash frame (**Fig. 62**). Reference Wiring Charts on [page 79 or 81](#) of this manual.

**NOTE:** It is important to remember that a solid electrical connection is essential when installing any electrical device or option. A proper crimp is shown in (**Fig. 63**).

- Find a suitable location to route the wiring harness out of the cab area and to the location of the manifold. Make sure wiring is clear of driveline and exhaust.

**CAUTION:** Apply battery voltage to the Diesel "PTO" or "Gas PTO - Mode" (Circuit #2242), MY2008 (#CE912) wire is what the transmission looks for to initiate commands. Failing to do so may show up as low or oscillating hydraulic line pressure and low or no PTO torque or pump flow output. Any attempt to operate the Power Take-Off at elevated idle without these commands may result in under-capacity PTO clutch wear, resulting in rapid contamination of transmission fluid and internal transmission damage. This applies to both stationary and mobile automatic transmission PTO operations. Reference Wiring charts on [pages 79 or 81](#).

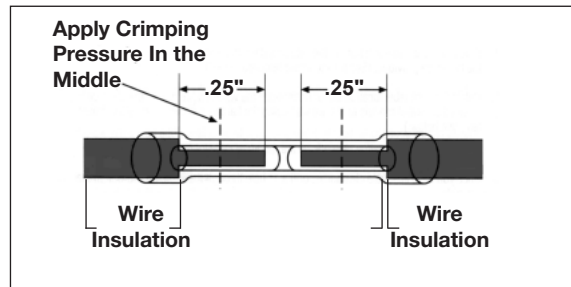

Figure 63

**Ford LCF/International CF Overview MY2006-MY2010**

Utilizing Chelsea wiring harness to wire a 247 Series PTO into a Ford LCF/International CF MY2006-MY2010.

**CAUTION:** Installing a transmission-mounted PTO without the required PTO wiring may result in transmission failure. To minimize the risk of transmission damage, PTO controls must be integrated into the vehicle wiring.

**NOTE:** Installation requires the lengthening and splicing of the MY2017 Chelsea harness.

**Follow the normal PTO installation instructions provided**

- Installer supplied wire will connect between the Chelsea supplied butt connectors (SK-448 or SK-449) and the OE supplied blunt connectors located in the blunt cut wiring bundle on the left side of the transmission (**Fig. 64**).

**Chelsea switch panel mounting suggestion**

- Switch panel may be located in cavity below the lighter (**Fig. 65**).

**NOTE:** Clearance cut required for fitment.

- Relocate the relay located on the back of the Chelsea switch panel. It is adhered with double stick tape (**Fig. 66**).

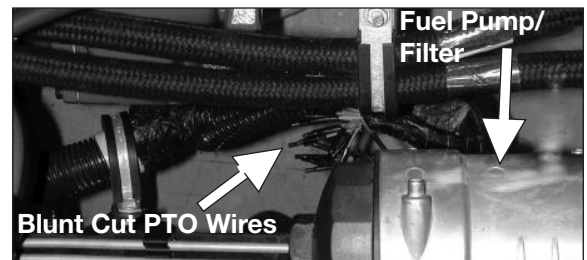

Figure 64



Figure 65



Figure 66

## 247 Series Installation Instructions

### Mounting the PTO

**CAUTION:** When installing the PTO, always wear protective clothing and safety glasses.

Installation of a 247 PTO will be faster and easier if several steps are completed before mounting the unit to the transmission. On a clean secure work surface complete the following steps.

1. There are two split dowels that will act as guides when installing the PTO to the transmission. Gently squeeze the dowel together and install in the top and lower right side mounting hole of the PTO as shown in **Fig. 67**. The dowel should be flush with the side away from the mounting face (**Fig. 67 and Fig. 68**) and protrude into the corresponding mounting holes of the transmission aperture when installing the PTO.
2. Before installing the PTO remove the shift cable bracket that is to the right side of the PTO aperture. Use a 14 mm wrench to remove the two cap screws. Remove the cable from the transmission range selector by pulling it straight off. Place the bracket and cable on the top of the transmission to allow easier installation of the PTO.

**NOTE:** On some early production Ford Super Dutys, the shifter bracket design was changed by about 3 mm. The increase in size of the bracket interfered with the Power Take-Off. See appendix for Ford approved modification of this bracket for PTO clearance.

**This transmission does not require the oil to be drained for PTO installation but expect some oil to weep when covers and plugs are removed.**

**! WARNING:** Oil may be hot. Use extreme caution to assure that you do not accidentally come in contact with hot oil.

3. Remove the plug from the transmission pressure port (**Fig. 69**) and install the 90-degree male elbow in the opening. Position the fitting (**Fig. 70**) at a 10 O'clock position as you look at the fitting.



Figure 67

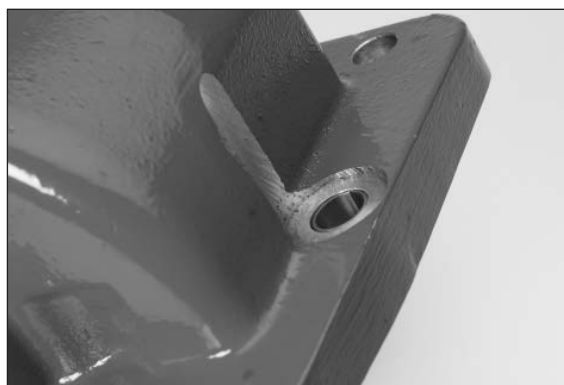

Figure 68

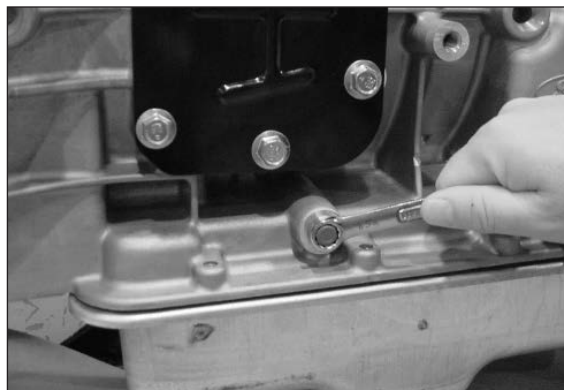

Figure 69



Figure 70

**! This symbol warns of possible personal injury.**

**Mounting the PTO (Cont'd)**

- Remove the PTO aperture cover plate and gasket (**Fig. 71**).

**IMPORTANT:** Discard the gasket. It will **NOT** be used when installing the PTO on the transmission.

**NOTE:** All hose routing described herein is the recommended routing for the 6.8L gas engine. Other hose routing options may be required depending on the chassis model (4x2 or 4x4) and or engine selection (6.8L Gas or 6.0L Diesel).

- Connect hose (Transmission-to-Hydraulic Valve) to the fitting on the transmission. Route as shown in (**Fig. 72**). Hold hose fitting in desired position and tighten lock nut with a wrench until solid feeling is encountered. From that point, apply one-sixth turn.

- Six fasteners (**Fig. 73**) are used to attach the PTO to the transmission opening. The longest bolt requires an O-ring on it to ensure a positive seal. Slide this on now after applying lube to the O-ring.

- Slide the special gasket supplied with the PTO over the split dowels (**Fig. 74**) installed in the PTO. This is the controlled compression gasket that is used to eliminate the setting of the gear backlash between the PTO and transmission.

**NOTE: DO NOT** use sealing compounds because they are generally incompatible with automatic transmission fluids and could possibly contaminate valve bodies in the transmission.

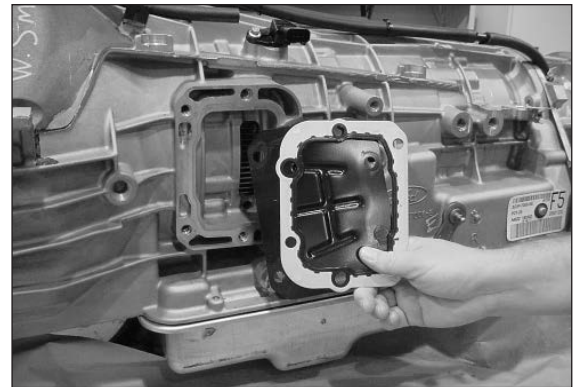

Figure 71

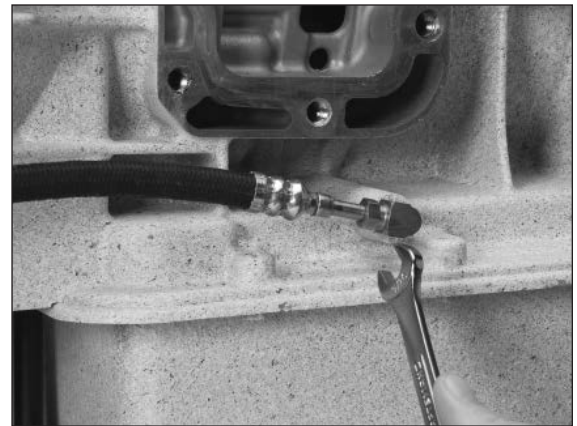

Figure 72



Figure 73



Figure 74

## 247 Series Installation Instructions

### Mounting the PTO (Cont'd)

8. Install the stud from the stud kit in the top hole on the transmission PTO aperture pad (**Fig. 75**).



Figure 75

9. Tighten the stud and torque to 17-19 lb-ft [23-26 N-m].

**CAUTION: Overtightening of the stud may damage stud and/or transmission threads.**

10. Mount the PTO to the transmission at this time by sliding the top PTO mounting hole w/ dowel pin over the shoulder stud. Guide other dowel pin into hole (**Fig. 76**).

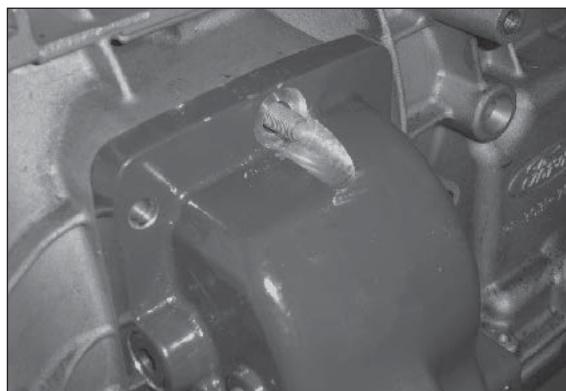

Figure 76

11. Attach the self-locking nut to the shoulder stud. **DO NOT** tighten down at this time (**Fig. 77**).

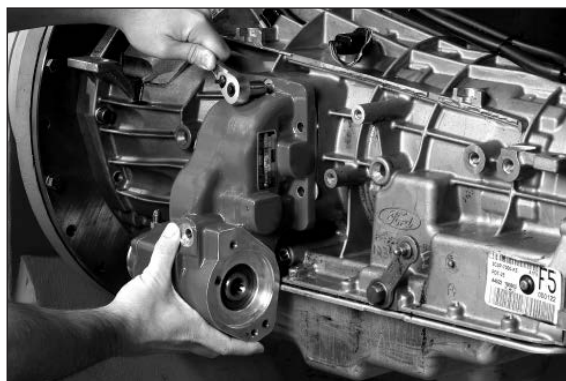

Figure 77

12. Make sure the O-ring from the stud kit is still on the longer hex head cap screw. Install this hex head cap screw and O-ring in the bottom mounting hole finger tight (**Fig. 78**).

**IMPORTANT:** Make sure the O-ring is positioned in the counter bore.

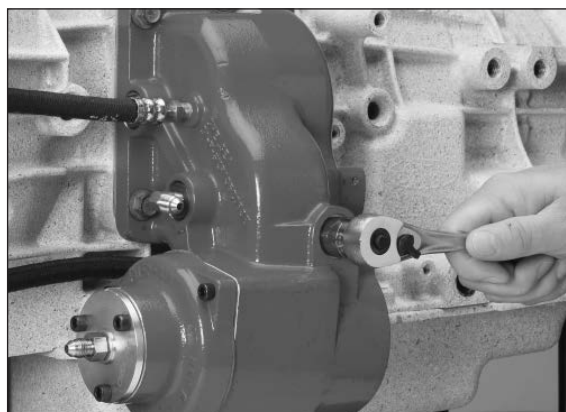

Figure 78

**Mounting the PTO (Cont'd)**

- 13. Finish fastening the PTO to the transmission using the remaining (4) flange head hex bolts.
- 14. Torque all 5 cap screws (**Fig. 79**) to 25 lb-ft [34 N-m] and torque the self-locking nut to 35-40 lb-ft [48-54 N-m].
- 15. Reinstall the cable to the transmission selector and reattach the bracket that was removed in Step 14. Torque cap screws to 22-29 lb-ft [30-40 N-m].
- 16. Install Transmission-to-Solenoid hose to the Hydraulic Valve Bearing Cap 90-degree Elbow fitting (**Fig. 80**).
- 17. Install PTO Pressure Switch into port on Hydraulic Valve Cap. Torque to 10-12 lb-ft [13.56-16.27 N-m](**Fig. 81**).
- 18. Install hydraulic pump or driveline as necessary. See [page 47](#) for more pump mounting information.

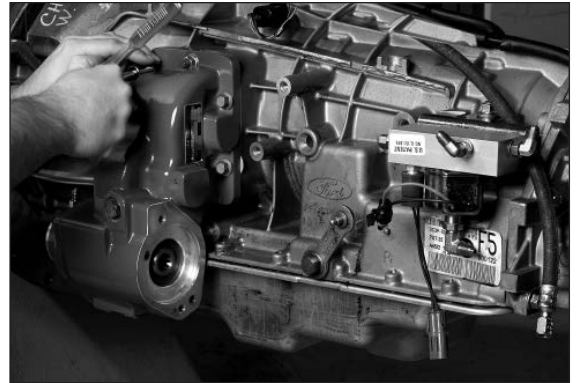

Figure 79



Figure 80



Figure 81

**Potentiometer Settings**

Charts are located in the Appendix on [pages 82-84](#).

CHASSIS	FUEL	MY2009	MY2010	MY2011	MY2012	MY2013	MY2014	MY2015	MY2016
Super Duty F-250-F-550	Gas	Chart I	Chart I	Chart I	Chart I	Chart I	Chart I	Chart I	Chart III
	Diesel	Chart I	Chart I	Chart II	Chart II	Chart II	Chart II	Chart II	Chart III

**Hose Assembly Identification Chart**

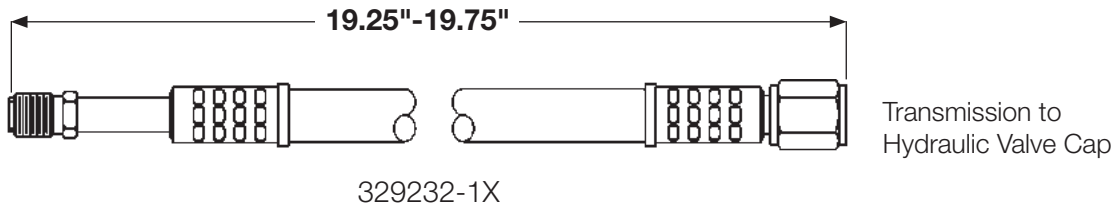

**Wiring Installation (Shift Option B)**

**(SK-448 Rev C)**

**Super Duty F-250-F-550 – MY2005-MY2010 – Diesel/Gas**  
**Super Duty F-250-F-550 – MY2011-MY2016 – 6.8L Gas**  
**Super Duty F-250-F-550 – MY2006-MY2010 – LCF**  
**w/o Electronic Overspeed Control (EOC)**

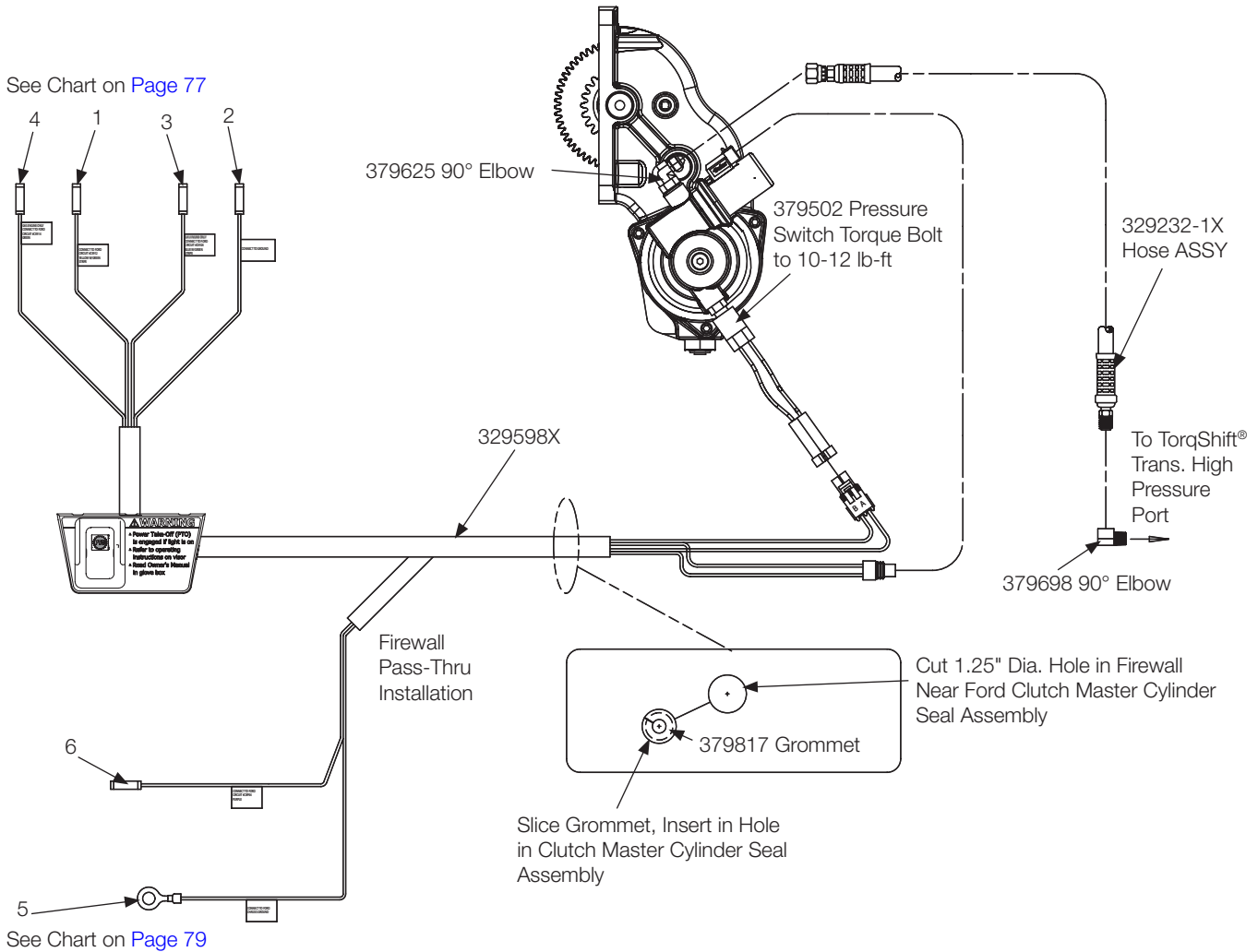

**Wiring Installation Chart (Shift Option B)  
w/o Electronic Overspeed Control (EOC)**

(SK-448 Rev C)

MY2005-MY2010 Ford Super Duty – Diesel/Gas (Stationary Mode Only)						
Chelsea PTO Wire Harness		MY2005-MY2007 Connect to Ford Wire Number		Gas/Diesel	*MY2008-MY2010 Connect to Ford Wire Number	
		Ford Wire Color	Circuit		Ford Wire Color	Circuit
1 or	Orange			Both	Yellow/Green	#CE912
1	Orange	Orange	#2242	Diesel Only		
2	Black w/ Butt Connector	Orange/Light Blue <sup>(1)</sup>	#2244	Both	Blue/White <sup>(1)</sup>	#CE326
3	Yellow	Orange/White	#2243	Gas Only	Blue/Green	#CE924
4	Red	Orange/Yellow	#2246	Gas Only	Green	#CE914
5	Black w/ Ring Terminal	Connect to Dash Chassis Ground		Both	Connect to Dash Chassis Ground	
6	White/Light Blue	White/Blue	#294	Both	Purple	#CE914

**NOTE:** <sup>(1)</sup> For Mobile Operation Only Connect Black Wire w/ Butt Connector to Chassis Ground  
\* 2011 Gas Engine Only

MY2011-MY2016 Ford Super Duty – 6.8L Gas (Stationary Mode Only)				
Chelsea PTO Wire Harness		Gas	MY2011 <sup>(1)</sup> Connect to Ford Wire Number	
			Ford Wire Color	Circuit
1	Orange	Gas Only	Yellow/Green	#CE912
2	Black w/ Butt Connector	Gas Only	Blue/White	#CE326
3	Yellow	Gas Only	Blue/Orange	#CE933
4	Red	Gas Only	Green	#CE914
5	Black w/ Ring Terminal	Gas Only	Connect to Dash Chassis Ground	
6	White/Light Blue	Gas Only	White/Blue <sup>(2)</sup>	#CDC64

**NOTE:** <sup>(1)</sup> MY2011-MY2012 Gas Engine Only.  
<sup>(2)</sup> Trucks built prior to May 15, 2010 this Ford wire is Yellow w/ Orange Stripe.

*MY2006-MY2010 Ford & International LCF			
Chelsea PTO Wire Harness		Connect to Ford Wire Number	
		Ford Wire Color	Circuit
1	Orange	Purple/Light Green	#2335
1	Orange	Light Blue/Red	#2231
1	Orange	Dark Green/White	#1924
2	Black w/ Butt Connector	Brown/Yellow	#2334
3	Yellow	Not Used	
4	Red	Not Used	
5	Black w/ Ring Terminal	Connect to Dash Chassis Ground	
6	White/Light Blue	Dark Green/Yellow	#2335

\* **NOTE:** Installer must provide wires to connect between the vehicle blunt wire connections and the Chelsea Wiring Harness 329598X.

**247 Series Installation Sketches**

**Wiring Installation (Shift Option K)**  
**Super Duty F-250-F-550 – MY2005-MY2016 – 6.8L Gas**  
**Super Duty F-250-F-550 – MY2005-MY2010 – 6.0L/6.4L Diesel**  
**LCF – MY2005-MY2009**  
**w/ Electronic Overspeed Control (EOC)**

**(SK-474 Rev A)**

Installation Kits: 329255-12X  
 329601X

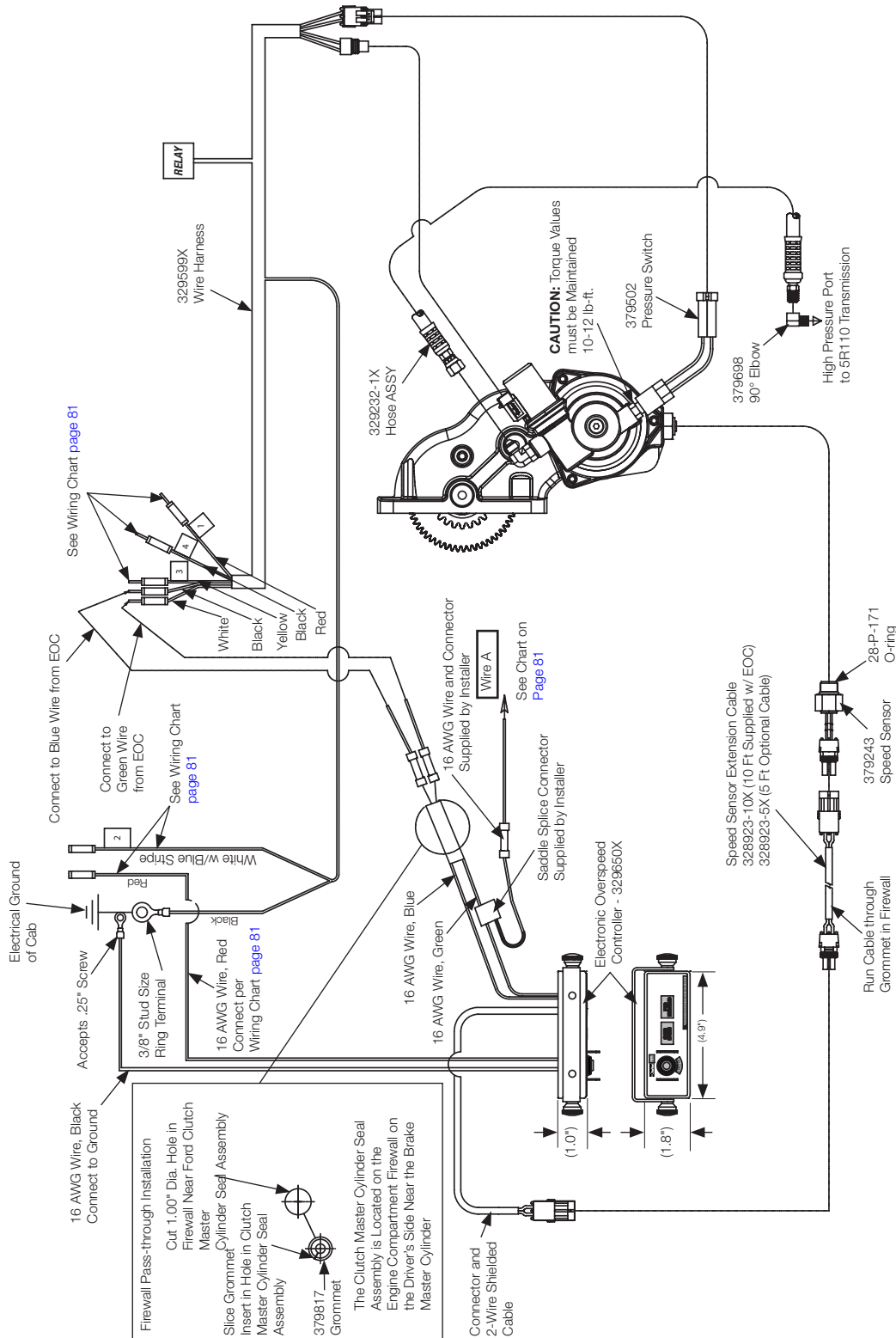

**NOTE:** Strip Wire Ends 0.25" Prior to Installing Connector.

**Wiring Installation Chart (Shift Option K)  
w/ Electronic Overspeed Control (EOC)****(SK-474 Rev A)**

Chelsea Wire	2005-2007 Super Duty 6.0L Diesel	2005-2007 Super Duty 6.8L Gas	2008-2010 Super Duty 6.4L Diesel	2008-2010 Super Duty 6.8L Gas	2005-2009 LCF 4.5L Diesel	2011-2016 Super Duty 6.8L Gas
1	Not Used	Ford Circuit #2246 Orange/Yellow	Not Used	Ford Circuit #CE914 Green	Not Used	Ford Circuit #CE914 Green
2	Not Used	Ford Circuit #294 White/Light Blue	Not Used	Ford Circuit #CBP44 Purple	Not Used	Ford Circuit #CDC64 White/Blue <sup>(1)</sup>
3	Not Used	Ford Circuit #2243 Orange/White	Not Used	Ford Circuit #CE924 Blue/Green	Not Used	Ford Circuit #CE933 Blue/Orange
4	Ground	Ford Circuit #2244 Orange/Light Blue	Ground	Ford Circuit #CE326 Blue/White	Ground	Ford Circuit #CE326 Blue/White
EOC Box Wire A	Ford Circuit #2242 Orange	Ford Circuit #2242 Orange	Ford Circuit #CE912 Yellow/Green	Ford Circuit #CE912 Yellow/Green	Ford/International Circuit #2335 Purple/Light Green	Ford Circuit #CE912 Yellow/Green
EOC Box Red	Ford Circuit #294 White/Light Blue	Ford Circuit #294 White/Light Blue	Ford Circuit #CBP44 Purple	Ford Circuit #CBP44 Purple	Ford/International Circuit #1043 Dark Green/Yellow	Ford Circuit #CDC64 White/Blue <sup>(1)</sup>

**NOTE:** <sup>(1)</sup> Trucks built after May 15, 2010. Trucks built prior to May 15, 2010 this Ford wire is Yellow/Orange Stripe.

Appendix

Potentiometer Settings

Potentiometer Settings - See Chart Number in corresponding box											
CHASSIS	FUEL	MY2009	MY2010	MY2011	MY2012	MY2013	MY2014	MY2015	MY2016	MY2017-MY2019	MY2020
Super Duty F-250-F-550	Gas	Chart I	Chart I	Chart I	Chart I	Chart I	Chart I	Chart I	Chart III	Chart IV	
	Diesel	Chart I	Chart I	Chart II	Chart II	Chart II	Chart II	Chart II	Chart III	Chart IV	
Medium Duty F-650/F-750	Gas				Chart I	Chart I	Chart I	Chart I	Chart III	Chart IV	Chart V
	Diesel								Chart III	Chart IV	Chart V

Chart I

Super Duty F-250-F-550 – 6.8L Gas MY2009-MY2015			247 Series PTO	Super Duty F-250-F-550 – 6.8L Diesel MY2009-MY2010			247 Series PTO	
Medium Duty F-650/F-750 – 6.8L Gas MY2012-MY2015			249G Series PTO	Engine Target Speed (RPM)			Resistor (Ohms)	Voltage (Volts)
650 (Base)				680 (Base)				
900	Open Circuit*			1200	Open Circuit*			
912	3.9K			1200	43K			
1024	2.7K	3.61		1260	27K	0.688		
1056	2.2K	4.18		1320	22K	0.888		
1184	1.8K	4.80		1380	16K	1.088		
1264	1.5K	5.39		1440	13K	1.288		
1440	1.0K	6.76		1500	11K	1.488		
1536	820	7.43		1560	9K	1.688		
1648	680	8.06		1620	7.5K	1.888		
1712	560	8.70		1680	6.2K	2.088		
1792	470	9.25		1740	5.6K	2.288		
1904	380	9.89		1800	4.7K	2.488		
1936	330	10.27		1860	3.9K	2.688		
2000	279	10.75		1920	3.3K	2.888		
2064	220	11.20		1980	2.7K	3.088		
2128	180	11.60		2040	2.4K	3.288		
2160	150	11.90		2100	2.0K	3.488		
2208	120	12.23		2160	1.6K	3.688		
2256	100	12.46		2220	1.3K	3.888		
2320	0 (Closed Circuit)	13.77		2280	1.0K	4.088		
* TorqShift® automatic transmission only; manual transmission requires a resistor.				2340	750	4.288		
				2400	510	4.488		

Chart II

Super Duty F-250-F-550 – 6.7L Diesel MY2011-MY2015		249F Series PTO
Engine Target Speed (RPM)	Resistor (Ohms)	* Voltage (Volts)
680 (Base)		
900	51K	0.400
1000	36K	0.590
1200	20K	0.971
1400	12K	1.352
1600	9100	1.733
1800	6200	2.114
2000	4700	2.495
2200	3300	2.876
2400	2400	3.257
2600	1800	3.638
2800	1100	4.019
3000	680	4.400

\* Voltage Reading - Chelsea Wiring Harness "PTO\_RPM" Green Wire.



Appendix

Potentiometer Settings (Cont'd)

Chart V

Medium Duty F-650/F-750 – 6.7L Diesel MY2020-MY2025		
Non-Split Shaft Mode		
Engine Target Speed (RPM)	Resistor (Ohms)	Voltage (volts)
900	54050	0.40
1000	35098	0.59
1100	25391	0.78
1200	19491	0.97
1300	15525	1.16
1400	12677	1.35
1500	10531	1.54
1600	8858	1.73
1700	7515	1.92
1800	6415	2.11
1900	5496	2.30
2000	4718	2.50
2100	4050	2.69
2200	3471	2.88
2300	2963	3.07
2400	2515	3.26
2500	2116	3.45
2600	1759	3.64
2700	1438	3.83
2800	1147	4.02
2900	883	4.21
3000	641	4.40

Medium Duty F-650/F-750 – 6.7L Diesel MY2020-MY2025		
Split Shaft Mode		
Engine Target Speed (RPM)	Resistor (Ohms)	Voltage (volts)
700	54050	0.40
800	36247	0.57
900	26724	0.75
1000	20795	0.92
1100	16748	1.10
1200	13810	1.27
1300	11580	1.44
1400	9830	1.62
1500	8419	1.79
1600	7258	1.97
1700	6286	2.14
1800	5460	2.31
1900	4749	2.49
2000	4132	2.66
2100	3590	2.83
2200	3111	3.01
2300	2684	3.18
2400	2301	3.36
2500	1956	3.53
2600	1644	3.70
2700	1359	3.88
2800	1099	4.05
2900	861	4.23
3000	641	4.40

Medium Duty F-650/F-750 – 6.7L Diesel MY2020-MY2025		
Mobile Mode		
Engine Target Speed (RPM)	Resistor (Ohms)	Voltage (volts)
900	54050	0.40
1000	35098	0.59
1100	25391	0.78
1200	19491	0.97
1300	15525	1.16
1400	12677	1.35
1500	10531	1.54
1600	8858	1.73
1700	7515	1.92
1800	6415	2.11
1900	5496	2.30
2000	4718	2.50
2100	4050	2.69
2200	3471	2.88
2300	2963	3.07
2400	2515	3.26
2500	2116	3.45
2600	1759	3.64
2700	1438	3.83
2800	1147	4.02
2900	883	4.21
3000	641	4.40

Medium Duty F-650/F-750 – 7.3L Gas MY2020-MY2025		
Non-Split Shaft Mode		
Engine Target Speed (RPM)	Resistor (Ohms)	Voltage (volts)
700	54050	0.40
800	32291	0.64
900	22293	0.87
1000	16550	1.11
1100	12822	1.34
1200	10207	1.58
1300	8271	1.81
1400	6780	2.05
1500	5596	2.28
1600	4634	2.52
1700	3836	2.75
1800	3164	2.99
1900	2590	3.22
2000	2094	3.46
2100	1661	3.69
2200	1281	3.93
2300	943	4.16
2400	641	4.40

Medium Duty F-650/F-750 – 7.3L Gas MY2020-MY2025								
Mobile Mode								
Engine Target Speed (RPM)	Resistor (Ohms)	Voltage (volts)	Engine Target Speed (RPM)	Resistor (Ohms)	Voltage (Volts)	Engine Target Speed (RPM)	Resistor (Ohms)	Voltage (Volts)
900	54050	0.40	2800	8674	1.76	4700	2846	3.11
1000	45148	0.47	2900	8152	1.83	4800	2677	3.19
1100	38589	0.54	3000	7668	1.90	4900	2515	3.26
1200	33556	0.61	3100	7220	1.97	5000	2360	3.33
1300	29571	0.69	3200	6803	2.04	5100	2212	3.40
1400	26338	0.76	3300	6415	2.11	5200	2070	3.47
1500	23662	0.83	3400	6052	2.19	5300	1933	3.54
1600	21411	0.90	3500	5711	2.26	5400	1802	3.61
1700	19491	0.97	3600	5392	2.33	5500	1676	3.69
1800	17834	1.04	3700	5092	2.40	5600	1555	3.76
1900	16390	1.11	3800	4809	2.47	5700	1438	3.83
2000	15119	1.19	3900	4542	2.54	5800	1326	3.90
2100	13993	1.26	4000	4289	2.61	5900	1217	3.97
2200	12988	1.33	4100	4050	2.69	6000	1113	4.04
2300	12086	1.40	4200	3823	2.76	6100	1012	4.11
2400	11271	1.47	4300	3608	2.83	6200	914	4.19
2500	10531	1.54	4400	3403	2.90	6300	820	4.26
2600	9858	1.61	4500	3209	2.97	6400	729	4.33
2700	9241	1.69	4600	3023	3.04	6500	641	4.40

Appendix

Installing the PTO Heat Shield – GAS Engines ONLY (After April 2017)

Heat Shield A

1. Locate and unplug the O<sub>2</sub> sensor.
2. Install heat shield (A) with the hole over the O<sub>2</sub> sensor.
3. Wrap heat shield around the exhaust pipe overlapping the seam. Seam should be facing the ground.
4. Make sure heat shield is snug against the bend at the forward end of the heat shield.
5. Install (8) clamps as shown in (Fig. 82).

Heat Shield B

1. Install piece (B) on the downward bend of the exhaust pipe adjacent to heat shield (A).
2. Lap ears of heat shield (B) over the ears of heat shield (A).
3. Seam of heat shield (B) should be facing forward of the truck.
4. Install (4) clamps as shown in (Fig. 82).

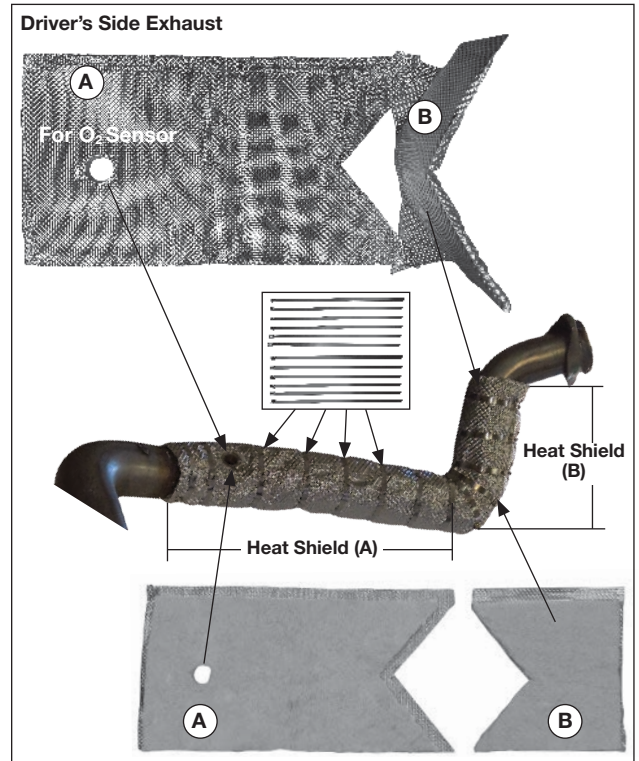

Figure 82

Installing the PTO Heat Shield – GAS Engines ONLY (Prior to April 2017)

1. Locate the Ford O<sub>2</sub> sensor located on the inside of the vertical exhaust pipe, located on the PTO side (approximately 3-4 inches above the top of the PTO) (Fig. 83).
2. Wrap the top of the heat shield material around the pipe just below the O<sub>2</sub> sensor, with the open end of the heat shield opposite the PTO (Fig. 84).
3. Secure (1) stainless steel clamp around the top of the heat shield, leaving approximately 1.0" of heat shield material exposed at the top of the clamp (Fig. 84).
4. Secure the second clamp at the 90-degree bend of the pipe. Ensure that the heat shield material is tight with the seam (split) remaining on the back side of the pipe opposite the PTO.
5. Install the third clamp equal distance between the 1st clamp and the 2nd clamp (elbow clamp).
6. Secure the fourth clamp approximately 8.0" to the right of the 90° elbow.
7. Attach the fifth clamp approximately 8.0" from clamp #4.

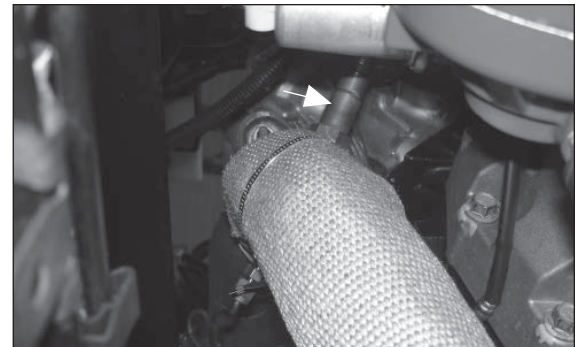

Figure 83

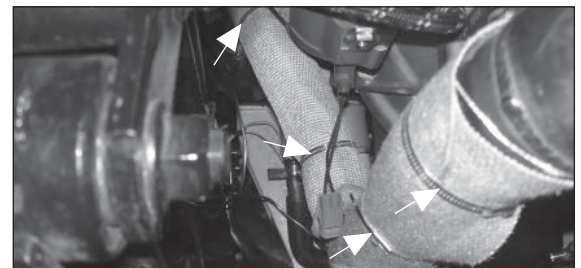
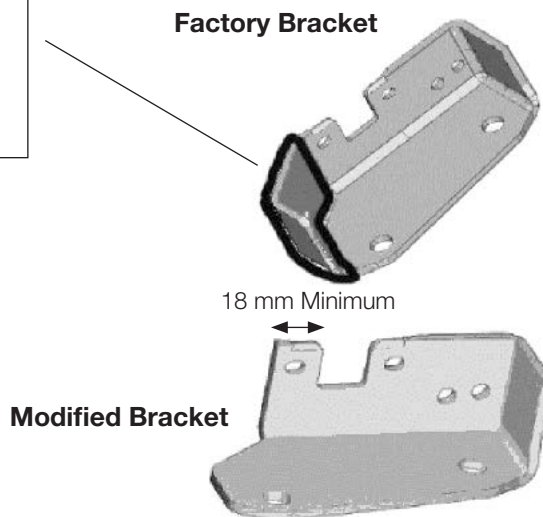

Figure 84

**NOTE:** The heat shield should end right at the pipe weld. There should be at least 1.0" of heat shield material exposed between the clamp and the pipe weld.

## TorqShift® Bracket – Field Modification MY2005

- Cut this area to eliminate interference with the PTO housing.
- Grind surface to eliminate sharp edges.
- Clean and paint the part with rust preventative.



**Models Affected:** 2005 Model Year F-250-F-550 with TorqShift® 5-Speed Automatic Transmission with PTO Provision Option.

**Background:** The shift bracket holding the shift linkage in position was revised for MY2005. That change resulted in the bracket interfering with the Chelsea and Muncie PTO by approximately 2.8 mm, preventing installation of the aftermarket PTO.

**Recommendation:** Grind or cut away a portion of the bracket to gain clearance. The illustration in the attachment to this bulletin depicts how much material may be removed without deteriorating the strength and reliability of the bracket and transmission gearshift function. Affected vehicles built approximately November 15<sup>th</sup>, 2004, will incorporate a revised shift bracket that provides clearance to the aftermarket PTO.

**WARNING:** The modification shown is the only one supported. No modifications to the bracket mounting holes are acceptable.

For additional questions please contact the Ford Truck Body Builders Advisory Service at toll-free number 1-877-840-4338, or by e-mail at [bbasqa@ford.com](mailto:bbasqa@ford.com). QVM Bulletins can be found at [www.fleet.ford.com/truckbbas](http://www.fleet.ford.com/truckbbas)

Ref: Ford SVE Bulletin Q-112 dated October 15, 2004.

**Appendix**

**Ford Shifter & Bracket Removal and Installation MY2016 & Prior**

**Removal**

1. Next the vehicle selector lever cable and bracket must be removed to help in the installation (**Fig. 85**).
2. The following instructions are Ford's recommended instructions for removal of the lever cable and bracket for PTO installation on the TorqShift® 6 transmission.

Item	Ford Part Number	Description
4	56539	Selector lever cable bracket bolts (2 required)
5	7B229	Selector lever cable bracket
6	7H181	Retaining clip

**NOTICE:** To prevent selector lever cable damage, **DO NOT** apply force to the selector lever cable assembly between the manual control lever and the selector lever cable bracket.

3. Position the vehicle selector lever into the drive position.
4. Disconnect the selector lever cable from the manual control lever (**Fig. 86**).
5. Remove and discard the selector lever cable retaining clip.
  - Lift the lock tabs on the retaining clip arms to release the clip.
  - Pull the clip and selector lever cable from the selector lever cable bracket (**Fig. 87**).

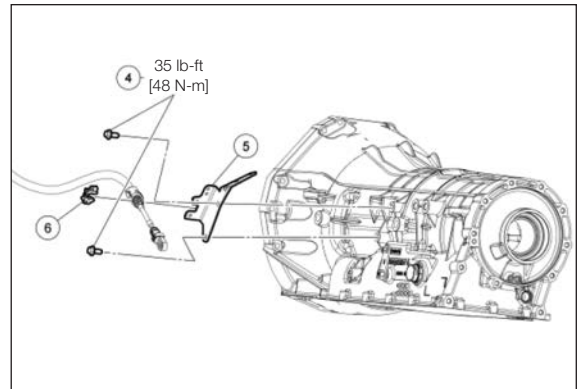

Figure 85

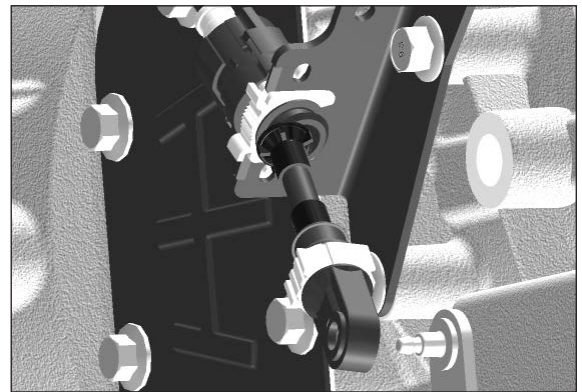

Figure 86

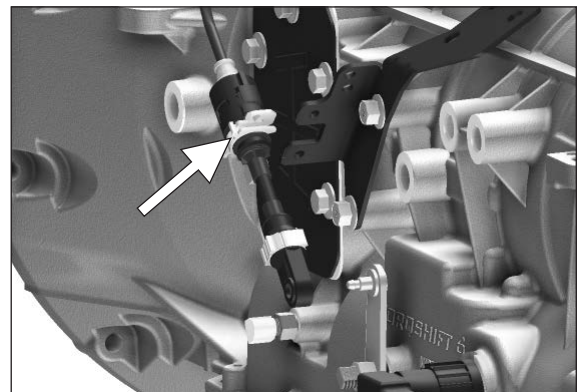

Figure 87

## Appendix

### Ford Shifter & Bracket Removal and Installation MY2016 & Prior (Cont'd)

#### Installation

6. Move the manual control lever all the way forward into the LOW position, then move it 3 detents rearward (**Fig. 88**).

**NOTE:** When installing the selector lever cable, make sure that the selector lever cable locking tabs are locked in place. Press the selector lever cable into the bracket and listen for the cable to click in place. Pull back on the selector lever cable to make sure that it is locked into the bracket.

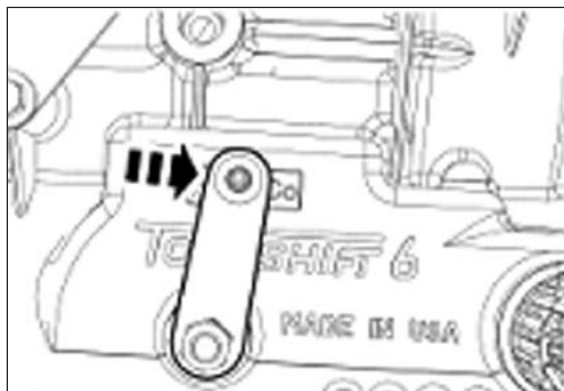

Figure 88

Install the selector lever cable into the selector lever cable bracket and install a new retaining clip.

7. Correct the selector lever cable onto manual control lever (**Fig. 89**).

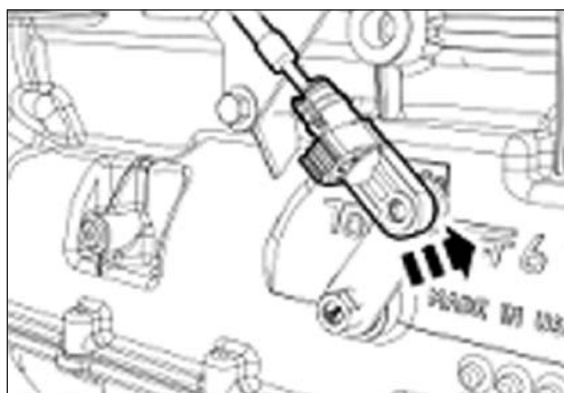

Figure 89

8. Slide the adjuster tab in place to lock the selector lever cable (**Fig. 90**).

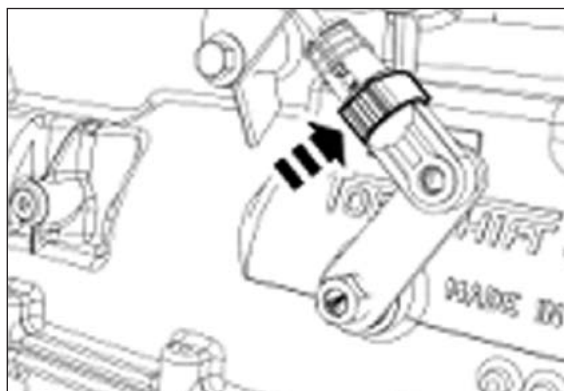

Figure 90

Appendix

Ford Shifter & Bracket Removal and Installation MY2017-MY2018

1. Clean the cable adjuster lock (Fig. 91).

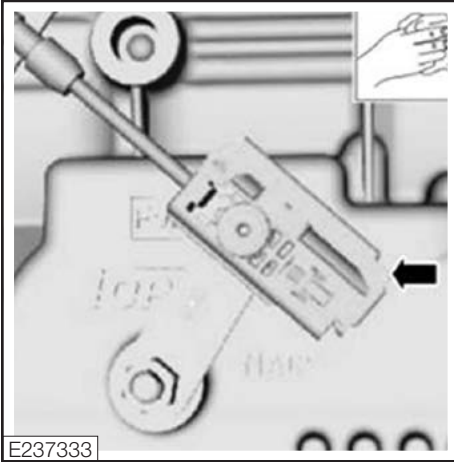

Figure 91

2. Open the adjuster lock (Fig. 92).

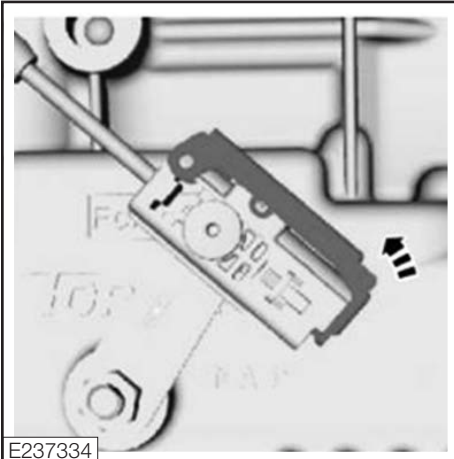

Figure 92

3. Disconnect the selector lever from the transmission manual lever (Fig. 93).

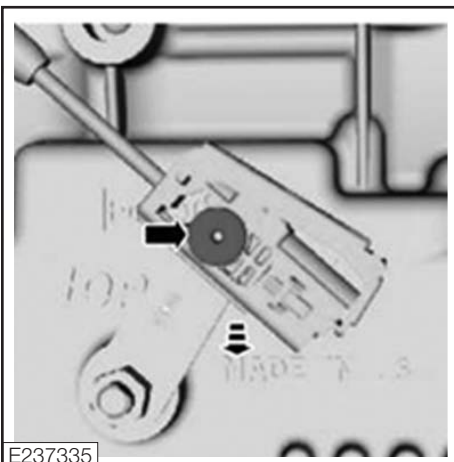

Figure 93

4. Remove the selector lever retainer bolt (Fig. 94).

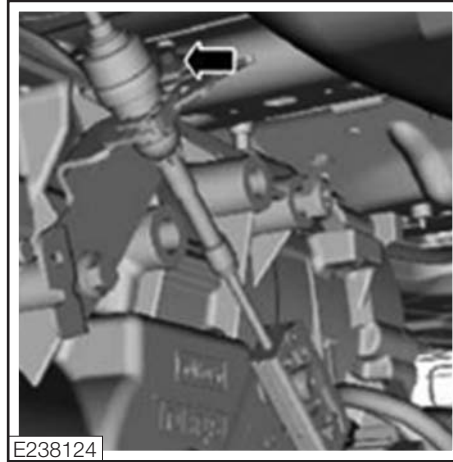

Figure 94

5. Remove the clip and the selector lever cable (Fig. 95).

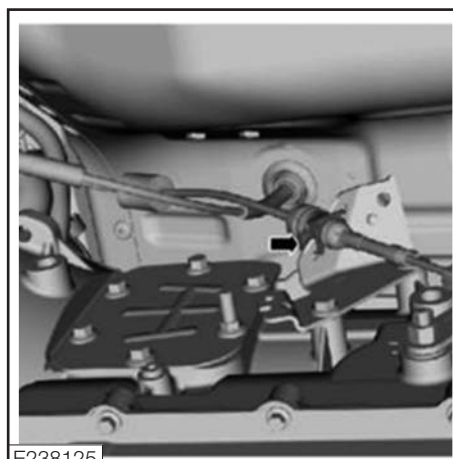

Figure 95

Installation

1. If necessary, open the adjuster lock (Fig. 96).

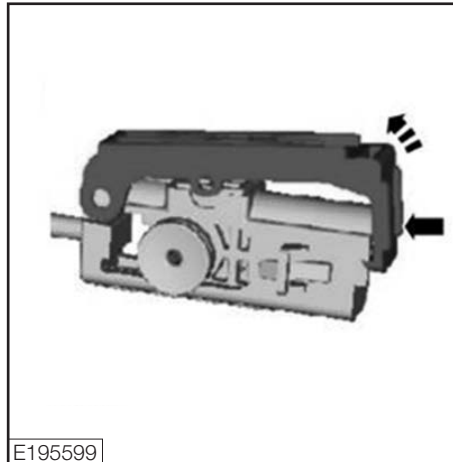

Figure 96

**NOTICE:** To prevent selector lever cable damage, **DO NOT** apply force to the selector lever cable between the manual control lever and the selector lever cable bracket.

Appendix

Ford Shifter & Bracket Removal and Installation MY2017-MY2018 (Cont'd)

2. Install the selector lever cable and the clip (Fig. 97).

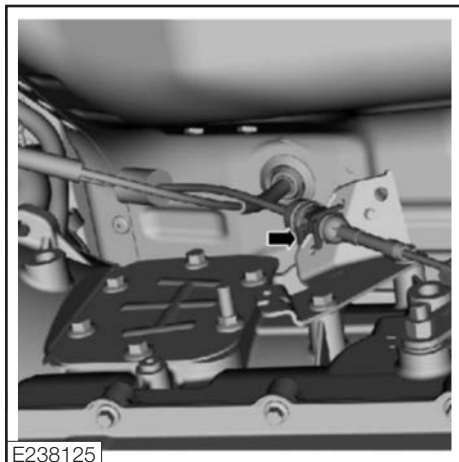

Figure 97

3. Install the selector lever retainer bolt. Torque to 62 lb-in [7 N-m] (Fig. 98).

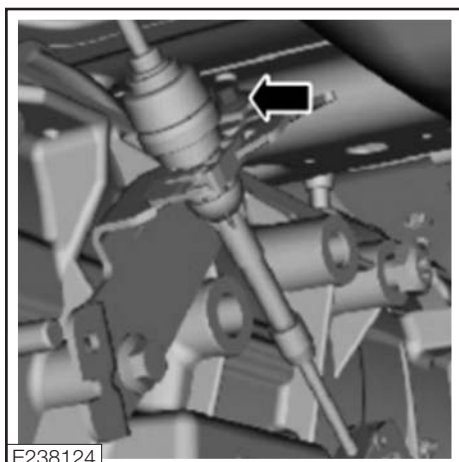

Figure 98

4. Verify the selector lever is in D (Fig. 99).

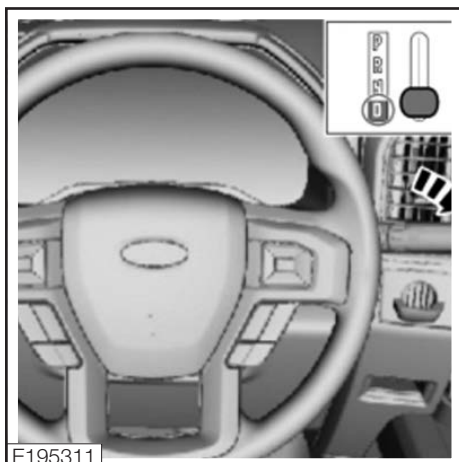

Figure 99

5. Position the manual lever in D.  
a. Rotate the manual lever clockwise until it stops.  
b. Rotate the manual lever counterclockwise 3 detents (Fig. 100).

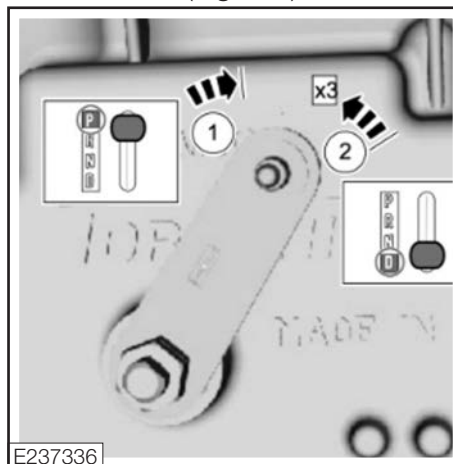

Figure 100

6. Connect the selector lever cable to the transmission manual lever (Fig. 101).

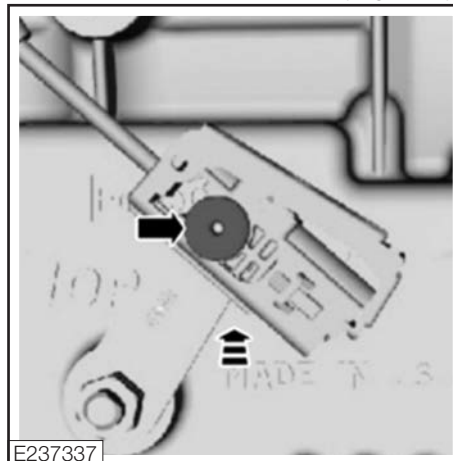

Figure 101

7. Close the adjuster lock (Fig. 102).

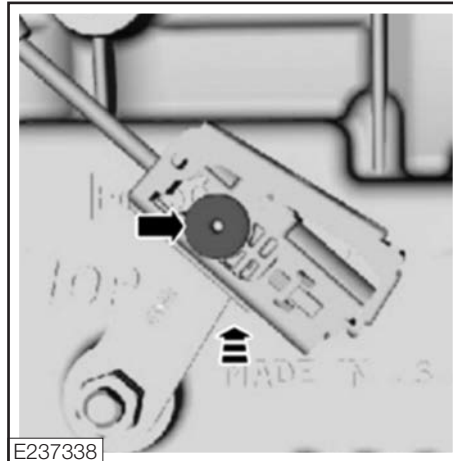

Figure 102

8. Verify the vehicle starts in P and N only and that the reverse lamps illuminate in R.

**Appendix**

**Chelsea – Ford Wiring Chart Diesel**

6.7L Diesel Harness P/N 329616X		Ford Wire Color, Diesel 6.7L (Reference Ford Bulletin Q-180, Q-236, Q256 and Q-312)					
		2011	2012-2015	2016	2017-2019	2020-2021	2025
Ford Function	Chelsea Wire Color						
	Chassis Group						
12VDC SOURCE	Purple	Yellow/Orange (Early) White/Blue (#CDC64)	White/Blue (#CDC64)	White/Blue (#CDC64) Yellow/Grey (#CBB35)	Ford Green/Orange F-250-F-550 Yellow/Grey F-650/F-750 (Pin 2) Chelsea - Purple	Grey (#CBK03)	Grey (#CBK03)
	Yellow	Yellow/Green	Yellow/Green	Yellow/Green	Stationary Mode Ford - Yellow/Green (Pin 7) Chelsea - Yellow	Yellow/Green (#CE912)	Yellow/Green (#CE912)
PTO REQUEST 1	Blue/Orange	Blue/Orange	Blue/Orange	Blue/Orange	Mobile Mode (Live Drive) Ford Blue/Orange F-250-F-550 Blue/Red F-650/F-750 (Pin 11) Chelsea - Yellow	Blue/Orange (#CE933)	Blue/Orange (#CE933)
	Blue/White	Blue/White	Blue/White	Blue/White	Ford - Blue/White (Pin 4) Chelsea - Blue/White	Blue/Grey (#CE326)	Blue/White (#CE326)
PTO RELAY	White	White/Brown	White/Brown	White/Brown	Ford - White/Brown (Pin 10) Chelsea - White/Brown	White/Brown (#LE434)	White/Brown (#LE434)
	Green	Green	Green	Green	Ford - Green (Pin 9) Chelsea - Green	Green (#CE914)	Green (#CE914)
PTO RPM	Grey	Grey/Violet	Grey/Violet	Grey/Violet	Ford - Grey/Violet (Pin 6) Chelsea - Grey/Violet	Grey/Violet (#RE327)	Grey/Violet (#RE327)
	Black w/ Ring Term.	Black w/ Ring Term.	Black w/ Ring Term.	Black w/ Ring Term.	Chassis Ground	Chassis Ground	Chassis Ground

Appendix

Chelsea – Ford Wiring Chart Gas

6.8L/7.3L Gas		Ford Wire Color, 6.8L/7.3L Gas (Reference Ford Bulletin Q-180, Q-236, Q-256 and Q-312)					
		2011	2012	2013-2015	2016	2017-2019	2020-2025
Ford Circuit	Chelsea Wire Color						
	White/Blue (247)	Yellow/Orange Early - White/Blue	White/Blue	White/Blue	White/Blue	Ford - Green/Orange (PIN 2) Chelsea - Yellow/Grey	
12VDC SOURCE	White Wire to Relay Harness attached to Battery Source		Blue IGN Wire Purple Pass-Thru Black	Blue IGN Wire Purple Pass-Thru Black			
	Yellow/Grey				Yellow/Grey	Ford - Yellow/Grey Chelsea - Yellow/Grey	Ford - Grey Chelsea - Yellow/Grey
	Orange (247)	Yellow/Green	Yellow/Green	Yellow/Green	Yellow/Green	Ford - Yellow/Green (PIN 7) Chelsea - Yellow/Blue	
PTO REQUEST 1	Yellow		White/Red Early - Yellow/Green	Yellow/Green	Yellow/Green	Stationary Mode	
	Yellow/Blue				Yellow/Blue Early - Yellow/Green	Ford - Yellow/Blue Chelsea - Yellow/Blue	Ford - Yellow/Green Chelsea - Yellow/ Blue
	Yellow (PTO_engage)	Blue/Orange	Blue/Orange	Blue/Orange	Blue/Orange	Ford - Blue/Orange (PIN 11) Chelsea - Yellow/Blue	
PTO REQUEST 2	Blue		Black/Orange Early - Blue/Orange	Blue/Orange	Blue/Orange	Mobile Mode (Live Drive)	
	Blue Yellow/Blue				Blue/Orange (Blue/Red eff. March 2016)	Ford - Blue/Red (PIN 11) Chelsea - Yellow/Blue	Ford - Blue/Orange Chelsea - Yellow/ Blue
	Black With Butt Conn.	Blue/White	Blue/White	Blue/White	Blue/White	Ford - Blue/White (PIN 4) Chelsea - Blue/White	
PTO RELAY	Blue/White		White/Purple Early - Blue/White	Blue/White	Blue/White	Ford - Blue/White Chelsea - Blue/White	Ford - Blue/White Chelsea - Blue/White
	Blue/White				Blue/White	Ford - Yellow/Green (PIN 18) Chelsea - Yellow/Green	
	Yellow/Green				Yellow/Green	Ford - Yellow/Green Chelsea - Yellow/Green	Ford - Yellow/Green Chelsea - Yellow/Green
PTO VREF	Red (247)	Green	Green	Green	Green	Ford - Green Chelsea - Green	
	Green		Tan/Orange Early - Green	Green	Green		
	Green				Green	Ford - Green Chelsea - Green	Ford - Green Chelsea - Green
PTO RPM	Green					Ford - Yellow/Violet Chelsea - Yellow/Violet	
	Green						
	Yellow/Violet				Yellow/Violet	Ford - Yellow/Violet Chelsea - Yellow/Violet	Ford - Yellow/Violet Chelsea - Yellow/Violet
PTO SIGRTN	Black w/ Ring Term.	Ground	Ground	Ground	Ground	Ground	
	Black w/ Ring Term.		Ground	Ground	Ground	Ground	
						Ground	Ground
GROUND							
							Ground

SD = Super Duty (F-250-F-550)/MD = Medium Duty (F-650/F-750).

**Offer of Sale**



**WARNING:** This product can expose you to chemicals including Lead and Lead Compounds, and Di(2-ethylhexyl)phthalate (DEHP) which are known to the State of California to cause cancer and birth defects or other reproductive harm. For more information go to [www.P65Warnings.ca.gov](http://www.P65Warnings.ca.gov)

**1. Definitions.** As used herein, the following terms have the meanings indicated.

**Buyer:** means any customer receiving a Quote for Products.

**Buyer's Property:** means any tools, patterns, plans, drawings, designs, specifications materials, equipment, or information furnished by Buyer, or which are or become Buyer's property.

**Confidential Information:** means any technical, commercial, or other proprietary information of Seller, including, without limitation, pricing, technical drawings or prints and/or part lists, which has been or will be disclosed, delivered, or made available, whether directly or indirectly, to Buyer.

**Goods:** means any tangible part, system or component to be supplied by Seller.

**Intellectual Property Rights:** means any patents, trademarks, copyrights, trade dress, trade secrets or similar rights.

**Products:** means the Goods, Services and/or Software as described in a Quote.

**Quote:** means the offer or proposal made by Seller to Buyer for the supply of Products.

**Seller:** means Parker-Hannifin Corporation, all divisions, subsidiaries and businesses selling products under these terms.

**Seller's IP:** means patents, trademarks, copyrights, or other intellectual property rights relating to the Products, including without limitation, names, designs, images, drawings, models, software, templates, information, any improvements or creations or other intellectual property developed prior to or during the relationship contemplated herein.

**Services:** means any services to be provided by Seller.

**Software:** means any software related to the Goods, whether embedded or separately downloaded.

**Special Tooling:** means equipment acquired by Seller or otherwise owned by Seller necessary to manufacture Goods, including but not limited to tools, jigs, and fixtures.

**Terms:** means the terms and conditions of this Offer of Sale.

**2. Terms.** All sales of Products by Seller will be governed by, and are expressly conditioned upon Buyer's assent to, these Terms. These Terms are incorporated into any Quote provided by Seller to Buyer. Buyer's order for any Products whether communicated to Seller verbally, in writing, by electronic data interface or other electronic commerce, shall constitute acceptance of these Terms. Seller objects to any contrary or additional terms or conditions of Buyer. Reference in Seller's order acknowledgement to Buyer's purchase order or purchase order number shall in no way constitute an acceptance of any of Buyer's terms or conditions of purchase. Any Quote made by Seller to Buyer shall be considered a firm and definite offer and shall not be deemed to be otherwise despite any language on the face of the Quote. Seller reserves all rights to accept or reject any purported acceptance by Buyer to Seller's Quote if such purported acceptance attempts to vary the terms of the Quote. If Seller ships Products after Buyer issues an acceptance to the Quote, any additional or different terms proposed by Buyer will not become part of the parties' business relationship unless agreed to in a writing that is signed by an authorized representative of Seller, excluding email correspondence. If the transaction proceeds without such agreement on the part of Seller, the business relationship will be

governed solely by these Terms and the specific terms in Seller's Quote.

**3. Price; Payment.** The Products set forth in the Quote are offered for sale at the prices indicated in the Quote. Unless otherwise specifically stated in the Quote, prices are valid for thirty (30) days and do not include any sales, use, or other taxes or duties. Seller reserves the right to modify prices for any reason and at any time by giving ten (10) days prior written notice. Unless otherwise specified by Seller, all prices are F.C.A. Seller's facility (INCOTERMS 2020). All sales are contingent upon credit approval and full payment for all purchases is due thirty (30) days from the date of invoice (or such date as may be specified in the Quote). Under any circumstances, Buyer may not withhold or suspend payment of any amounts due and payable as a deduction, set-off or recoupment of any amount, claim or dispute with Seller. Unpaid invoices beyond the specified payment date incur interest at the rate of 1.5% per month or the maximum allowable rate under applicable law. Seller reserves the right to require advance payment or provision of securities for first and subsequent deliveries if there is any doubt, in Seller's sole determination, regarding the Buyer's creditworthiness or for other business reasons. If the requested advance payment or securities are not provided to Seller's satisfaction, Seller reserves the right to suspend performance or reject the purchase order, in whole or in part, without prejudice to Seller's other rights or remedies, including the right to full compensation. Seller may revoke or shorten any payment periods previously granted in Seller's sole determination. The rights and remedies herein reserved to Seller are cumulative and in addition to any other or further rights and remedies available at law or in equity. No waiver by Seller of any breach by Buyer of any provision of these terms will constitute a waiver by Seller of any other breach of such provision.

**4. Shipment; Delivery; Title and Risk of Loss.** All delivery dates are approximate, and Seller is not responsible for damages or additional costs resulting from any delay. All deliveries are subject to our ability to procure materials from our suppliers. Regardless of the manner of shipment, delivery occurs and title and risk of loss or damage pass to Buyer, upon placement of the Products with the carrier at Seller's facility. Unless otherwise agreed prior to shipment and for domestic delivery locations only, Seller will select and arrange, at Buyer's sole expense, the carrier and means of delivery. When Seller selects and arranges the carrier and means of delivery, freight and insurance costs for shipment to the designated delivery location will be prepaid by Seller and added as a separate line item to the invoice. Buyer shall be responsible for any additional shipping charges incurred by Seller due to Buyer's acts or omissions. Buyer shall not return or repackage any Products without the prior written authorization from Seller, and any return shall be at the sole cost and expense of Buyer.

**5. Warranty.** The warranty for the Products is as follows: (i) Seller warrants that all products sold conform to the applicable Parker Chelsea standard specification for the lesser period of 2 years (24 Months) from date of service or 2-1/2 years (30 Months) from date of build (as marked on the product name plate); (ii) Services shall be performed in accordance with generally accepted practices and using the degree of care and skill that is ordinarily exercised and customary in the field to which the Services pertain and are warranted for a period of six (6) months from the date of completion of the Services; and (iii) Software is only warranted to perform in accordance with applicable specifications provided by Seller to Buyer for ninety (90) days from the date of delivery or, when downloaded by a Buyer or end-user, from the date of the initial download. All prices are based upon the exclusive limited warranty stated above, and upon the following disclaimer: **EXEMPTION CLAUSE; DISCLAIMER OF WARRANTY, CONDITIONS, REPRESENTATIONS: THIS WARRANTY IS THE SOLE AND ENTIRE WARRANTY, CONDITION, AND REPRESENTATION, PERTAINING TO PRODUCTS. SELLER**

Continued on Next Page

**Offer of Sale (Cont'd)**

**DISCLAIMS ALL OTHER WARRANTIES, CONDITIONS, AND REPRESENTATIONS, WHETHER STATUTORY, EXPRESS OR IMPLIED, INCLUDING BUT NOT LIMITED TO THOSE RELATING TO DESIGN, NONINFRINGEMENT, MERCHANTABILITY, AND FITNESS FOR A PARTICULAR PURPOSE. SELLER DOES NOT WARRANT THAT THE SOFTWARE IS ERROR-FREE OR FAULT-TOLERANT, OR THAT BUYER'S USE THEREOF WILL BE SECURE OR UNINTERRUPTED, UNLESS OTHERWISE AUTHORIZED IN WRITING BY SELLER, THE SOFTWARE SHALL NOT BE USED IN CONNECTION WITH HAZARDOUS OR HIGH-RISK ACTIVITIES OR ENVIRONMENTS. EXCEPT AS EXPRESSLY STATED HEREIN, ALL PRODUCTS ARE PROVIDED "AS IS".**

**6. Claims; Commencement of Actions.** Buyer shall promptly inspect all Products upon receipt. No claims for shortages will be allowed unless reported to Seller within ten (10) days of delivery. Buyer shall notify Seller of any alleged breach of warranty within thirty (30) days after the date the non-conformance is or should have been discovered by Buyer. Any claim or action against Seller based upon breach of contract or any other theory, including tort, negligence, or otherwise must be commenced within twelve (12) months from the date of the alleged breach or other alleged event, without regard to the date of discovery.

**7. LIMITATION OF LIABILITY. IN THE EVENT OF A BREACH OF WARRANTY, SELLER WILL, AT ITS OPTION, REPAIR OR REPLACE THE NON-CONFORMING PRODUCTS, RE-PERFORM THE SERVICES, OR REFUND THE PURCHASE PRICE PAID WITHIN A REASONABLE PERIOD OF TIME. IN NO EVENT IS SELLER LIABLE FOR ANY SPECIAL, INDIRECT, INCIDENTAL OR CONSEQUENTIAL DAMAGES INCLUDING ANY LOSS OF REVENUE OR PROFITS, WHETHER BASED IN CONTRACT, TORT OR OTHER LEGAL THEORY. IN NO EVENT SHALL SELLER'S LIABILITY UNDER ANY CLAIM MADE BY BUYER EXCEED THE PURCHASE PRICE PAID FOR THE PRODUCTS.**

**8. Confidential Information.** Buyer acknowledges and agrees that Confidential Information has been and will be received in confidence and will remain the property of Seller. Buyer further agrees that it will not use Seller's Confidential Information for any purpose other than for the benefit of Seller and shall return all such Confidential Information to Seller within thirty (30) days upon request.

**9. Loss to Buyer's Property.** Buyer's Property will be considered obsolete and may be destroyed by Seller after two (2) consecutive years have elapsed without Buyer ordering the Products manufactured using Buyer's Property. Also, Seller shall not be responsible for any loss or damage to Buyer's Property while it is in Seller's possession or control.

**10. Special Tooling.** Seller may impose a tooling charge for any Special Tooling. Special Tooling shall be and remain Seller's property. In no event will Buyer acquire any interest in the Special Tooling, even if such Special Tooling has been specially converted or adapted for manufacture of Goods for Buyer and notwithstanding any charges paid by Buyer. Unless otherwise agreed, Seller has the right to alter, discard or otherwise dispose of any Special Tooling or other property owned by Seller in its sole determination at any time.

**11. Security Interest.** To secure payment of all sums due from Buyer, Seller retains a security interest in all Products delivered to Buyer and, Buyer's acceptance of these Terms is deemed to be a Security Agreement under the Uniform Commercial Code. Buyer authorizes Seller as its attorney to execute and file on Buyer's behalf all documents Seller deems necessary to perfect Seller's security interest.

**12. User Responsibility.** Buyer, through its own analysis and testing, is solely responsible for making the final selection of the Products and assuring that all performance, endurance, maintenance, safety and warning requirements of the application of the Products are met. Buyer must analyze all aspects of the application and follow applicable industry standards, specifications, and any technical information provided with the Quote or the Products, such as Seller's instructions, guides and specifications. If Seller provides options of or for Products based upon data

or specifications provided by Buyer, Buyer is responsible for determining that such data and specifications are suitable and sufficient for all applications and reasonably foreseeable uses of the Products. In the event Buyer is not the end-user of the Products, Buyer will ensure such end-user complies with this paragraph.

**13. Use of Products, Indemnity by Buyer.** Buyer shall comply with all instructions, guides and specifications provided by Seller with the Quote or the Products. If Buyer uses or resells the Products in any way prohibited by Seller's instructions, guides or specifications, or Buyer otherwise fails to comply with Seller's instructions, guides and specifications, Buyer acknowledges that any such use, resale, or non-compliance is at Buyer's sole risk. Further, Buyer shall indemnify, defend, and hold Seller harmless from any losses, claims, liabilities, damages, lawsuits, judgments and costs (including attorney fees and defense costs), whether for personal injury, property damage, intellectual property infringement or any other claim, arising out of or in connection with: (a) improper selection, design, specification, application, or any misuse of Products; (b) any act or omission, negligent or otherwise, of Buyer; (c) Seller's use of Buyer's Property; (d) damage to the Products from an external cause, repair or attempted repair by anyone other than Seller, failure to follow instructions, guides and specifications provided by Seller, use with goods not provided by Seller, or opening, modifying, deconstructing, tampering with or repackaging the Products; or (e) Buyer's failure to comply with these Terms, including any legal or administrative proceedings, collection efforts, or other actions arising from or relating to such failure to comply. Seller shall not indemnify Buyer under any circumstance except as otherwise provided in these Terms.

**14. Cancellations and Changes.** Buyer may not cancel or modify, including but not limited to movement of delivery dates for the Products, any order for any reason except with Seller's written consent and upon terms that will indemnify, defend and hold Seller harmless against all direct, incidental and consequential loss or damage and any additional expense. Seller, at any time, may change features, specifications, designs and availability of Products.

**15. Assignment.** Buyer may not assign its rights or obligations without the prior written consent of Seller.

**16. Force Majeure.** Seller is not liable for delay or failure to perform any of its obligations by reason of any events or circumstances beyond its reasonable control. Such circumstances include without limitation: accidents, labor disputes or stoppages, government acts or orders, acts of nature, pandemics, epidemics, other widespread illness, or public health emergency, cyber related disruptions, cyber-attacks, ransomware sabotage, delays or failures in delivery from carriers or suppliers, shortages of materials, sudden increases in the price of raw material or components, shutdowns or slowdowns affecting the supply of raw materials or components, or the transportation thereof, oil shortages or oil price increases, energy crisis, energy or fuel interruption, war (whether declared or not) or the serious threat of same, riots, rebellions, acts of terrorism, embargoes, fire or any reason whether similar to the foregoing or otherwise. Seller will resume performance as soon as practicable after the event of force majeure has been removed. All delivery dates affected by an event of force majeure shall be tolled for the duration of such event of force majeure and rescheduled for mutually agreed dates as soon as practicable after the event of force majeure ceases to exist. The right to allocate capacity is in the Seller's sole discretion. An event of force majeure shall not include financial distress, insolvency, bankruptcy, or other similar conditions affecting one of the parties, affiliates and/or subcontractors. An event of force majeure in the meaning of these Terms means any circumstances beyond Seller's control that permanently or temporarily hinders performance, even where that circumstance was already foreseen. Buyer shall not be entitled to cancel any orders following its claim of an event of force majeure.

**17. Waiver and Severability.** Failure to enforce any provision of these Terms will not invalidate that provision; nor will any such

Continued on Next Page



failure prejudice either party's right to enforce that provision in the future. Invalidation of any provision of these Terms shall not invalidate any other provision herein and, the remaining provisions will remain in full force and effect.

**18. Duration.** Unless otherwise stated in the Quote, any agreement governed by or arising from these Terms shall: (a) be for an initial duration of one (1) year; and (b) shall automatically renew for successive one-year terms unless terminated by Buyer with at least 180-days written notice to Seller or if Seller terminates the agreement pursuant to Section 19 of these Terms.

**19. Termination.** Seller may, without liability to Buyer, terminate any agreement governed by or arising from these Terms for any reason and at any time by giving Buyer thirty (30) days prior written notice. Seller may immediately terminate, in writing, if Buyer: (a) breaches any provision of these Terms, (b) becomes or is deemed insolvent, (c) appoints or has appointed a trustee, receiver or custodian for all or any part of Buyer's property, (d) files a petition for relief in bankruptcy on its own behalf, or one is filed against Buyer by a third party, (e) makes an assignment for the benefit of creditors; or (f) dissolves its business or liquidates all or a majority of its assets.

**20. Ownership of Rights.** Buyer agrees that (a) Seller (and/or its affiliates) owns or is the valid licensee of Seller's IP and (b) the furnishing of information, related documents or other materials by Seller to Buyer does not grant or transfer any ownership interest or license in or to Seller's IP to Buyer, unless expressly agreed in writing. Without limiting the foregoing, Seller retains ownership of all Software supplied to Buyer. In no event shall Buyer obtain any greater right in and to the Software than a right in a license limited to the use thereof and subject to compliance with any other terms provided with the Software. Buyer further agrees that it will not, directly or through intermediaries, reverse engineer, decompile, or disassemble any Software (including firmware) comprising or contained within a Product, except and only to the extent that such activity may be expressly permitted, either by applicable law or, in the case of open-source software, the applicable open-source license.

**21. Indemnity for Infringement of Intellectual Property Rights.**

Seller is not liable for infringement of any Intellectual Property Rights except as provided in this Section. Seller will defend at its expense and will pay the cost of any settlement or damages awarded in an action brought against Buyer based on a third-party claim that one or more of the Products infringes the Intellectual Property Rights of a third party in the country of delivery of the Products by Seller to Buyer. Seller's obligation to defend and indemnify Buyer is contingent on Buyer notifying Seller within ten (10) days after Buyer becomes aware of any such claim, and Seller having sole control over the defense of the claim including all negotiations for settlement or compromise. If one or more Products is subject to such a claim, Seller may, at its sole expense and option, procure for Buyer the right to continue using the Products, replace or modify the Products to render them non-infringing, or offer to accept return of the Products and refund the purchase price less a reasonable allowance for depreciation. Seller has no obligation or liability for any claim of infringement: (i) arising from information provided by Buyer (including Seller's use of Buyer's Property); or (ii) directed to any Products for which the designs are specified in whole or part by Buyer; or (iii) resulting from the modification, combination or use in a system of any Products. The foregoing provisions of this Section constitute Seller's sole and exclusive liability and Buyer's sole and exclusive remedy for claims of infringement of Intellectual Property Rights.

**22. Governing Law.** These Terms, the terms of any Quote, and the sale and delivery of all Products are deemed to have taken place in, and shall be governed and construed in accordance with, the laws of the State of Ohio, as applicable to contracts executed and wholly performed therein and without regard to conflicts of laws principles. Buyer irrevocably agrees and consents to the exclusive jurisdiction and venue of the courts of Cuyahoga County, Ohio with respect to any dispute, controversy or claim arising out of or relating to the sale

and delivery of the Products.

**23. Entire Agreement.** These Terms, along with the terms set forth in the Quote, forms the entire agreement between the Buyer and Seller and constitutes the final, complete and exclusive expression of the terms of sale and purchase. In the event of a conflict between any term set forth in the Quote and these Terms, the terms set forth in the Quote shall prevail. All prior or contemporaneous written or oral agreements or negotiations with respect to the subject matter shall have no effect. No modification to these Terms will be binding on Seller unless agreed to in a writing that is signed by an authorized representative of Seller, excluding email correspondence, 'clickwrap' or other purported electronic assent to different or additional terms. Sections 2-25 of these Terms shall survive termination or cancellation of any agreement governed by or arising from these Terms.

**24. No 'Wrap' Agreements/No Authority to Bind.** Seller's clicking any buttons or any similar action, such as clicking "I Agree" or "Confirm," to utilize Buyer's software or webpage for the placement of orders, is NOT an agreement to Buyer's Terms and Conditions. **NO EMPLOYEE, AGENT OR REPRESENTATIVE OF SELLER HAS THE AUTHORITY TO BIND SELLER BY THE ACT OF CLICKING ANY BUTTON OR SIMILAR ACTION ON BUYER'S WEBSITE OR PORTAL.**

**25. Compliance with Laws.** Buyer agrees to comply with all applicable laws, regulations, and industry and professional standards, including those of the United States of America, and the country or countries in which Buyer may operate, including without limitation the U.S. Foreign Corrupt Practices Act ("FCPA"), the U.S. Anti-Kickback Act ("Anti-Kickback Act"), U.S. and E.U. export control and sanctions laws ("Export Laws"), the U.S. Food Drug and Cosmetic Act ("FDCA"), and the rules and regulations promulgated by the U.S. Food and Drug Administration ("FDA"), each as currently amended. Buyer agrees to indemnify, defend, and hold harmless Seller from the consequences of any violation of such laws, regulations and standards by Buyer, its employees or agents. Buyer represents that it is familiar with all applicable provisions of the FCPA, the Anti-Kickback Act, Export Laws, the FDCA and the FDA and certifies that Buyer will adhere to the requirements thereof and not take any action that would make Seller violate such requirements. Buyer represents and agrees that Buyer will not make any payment or give anything of value, directly or indirectly, to any governmental official, foreign political party or official thereof, candidate for foreign political office, or commercial entity or person, for any improper purpose, including the purpose of influencing such person to purchase Products or otherwise benefit the business of Seller. Buyer further represents and agrees that it will not receive, use, service, transfer or ship any Products from Seller in a manner or for a purpose that violates Export Laws or would cause Seller to be in violation of Export Laws. Buyer agrees to promptly and reliably provide Seller all requested information or documents, including end-user statements and other written assurances, concerning Buyer's ongoing compliance with Export Law.

09/22

# Parker Worldwide

## Europe, Middle East, Africa

**AE – United Arab Emirates,**  
Dubai

Tel: +971 4 8127100  
parker.me@parker.com

**AT – Austria,** Wiener Neustadt

Tel: +43 (0)2622 23501-0  
parker.austria@parker.com

**AT – Eastern Europe,** Wiener  
Neustadt

Tel: +43 (0)2622 23501 900  
parker.easteurope@parker.com

**AZ – Azerbaijan,** Baku

Tel: +994 50 22 33 458  
parker.azerbaijan@parker.com

**BE/LU – Belgium,** Nivelles

Tel: +32 (0)67 280 900  
parker.belgium@parker.com

**BG – Bulgaria,** Sofia

Tel: +359 2 980 1344  
parker.bulgaria@parker.com

**BY – Belarus,** Minsk

Tel: +375 17 209 9399  
parker.belarus@parker.com

**CH – Switzerland,** Etoy

Tel: +41 (0)21 821 87 00  
parker.switzerland@parker.com

**CZ – Czech Republic,** Klecany

Tel: +420 284 083 111  
parker.czechrepublic@parker.com

**DE – Germany,** Kaarst

Tel: +49 (0)2131 4016 0  
parker.germany@parker.com

**DK – Denmark,** Ballerup

Tel: +45 43 56 04 00  
parker.denmark@parker.com

**ES – Spain,** Madrid

Tel: +34 902 330 001  
parker.spain@parker.com

**FI – Finland,** Vantaa

Tel: +358 (0)20 753 2500  
parker.finland@parker.com

**FR – France,** Contamine s/Arve

Tel: +33 (0)4 50 25 80 25  
parker.france@parker.com

**GR – Greece,** Athens

Tel: +30 210 933 6450  
parker.greece@parker.com

**HU – Hungary,** Budaoers

Tel: +36 23 885 470  
parker.hungary@parker.com

**IE – Ireland,** Dublin

Tel: +353 (0)1 466 6370  
parker.ireland@parker.com

**IT – Italy,** Corisico (MI)

Tel: +39 02 45 19 21  
parker.italy@parker.com

**KZ – Kazakhstan,** Almaty

Tel: +7 7273 561 000  
parker.easteurope@parker.com

**NL – The Netherlands,** Oldenzaal

Tel: +31 (0)541 585 000  
parker.nl@parker.com

**NO – Norway,** Asker

Tel: +47 66 75 34 00  
parker.norway@parker.com

**PL – Poland,** Warsaw

Tel: +48 (0)22 573 24 00  
parker.poland@parker.com

**PT – Portugal,** Leca de Palmeira

Tel: +351 22 999 7360  
parker.portugal@parker.com

**RO – Romania,** Bucharest

Tel: +40 21 252 1382  
parker.romania@parker.com

**RU – Russia,** Moscow

Tel: +7 495 645-2156  
parker.russia@parker.com

**SE – Sweden,** Spånga

Tel: +46 (0)8 59 79 50 00  
parker.sweden@parker.com

**SK – Slovakia,** Banská Bystrica

Tel: +421 484 162 252  
parker.slovakia@parker.com

**SL – Slovenia,** Novo Mesto

Tel: +386 7 337 6650  
parker.slovenia@parker.com

**TR – Turkey,** Istanbul

Tel: +90 216 4997081  
parker.turkey@parker.com

**UA – Ukraine,** Kiev

Tel: +380 44 494 2731  
parker.ukraine@parker.com

**UK – United Kingdom,** Warwick

Tel: +44 (0)1926 317 878  
parker.uk@parker.com

**ZA – South Africa,** Kempton Park

Tel: +27 (0)11 961 0700  
parker.southafrica@parker.com

## North America

**CA – Canada,** Milton, Ontario

Tel: +1 905 693 3000

**MX – Mexico,** Toluca

Tel: +52 72 2275 4200

## Asia Pacific

**AU – Australia,** Castle Hill

Tel: +61 (0)2-9634 7777

**CN – China,** Shanghai

Tel: +86 21 2899 5000

**HK – Hong Kong**

Tel: +852 2428 8008

**IN – India,** Mumbai

Tel: +91 22 6513 7081-85

**JP – Japan,** Fujisawa

Tel: +81 (0)4 6635 3050

**KR – South Korea,** Seoul

Tel: +82 2 559 0400

**MY – Malaysia,** Shah Alam

Tel: +60 3 7849 0800

**NZ – New Zealand,** Mt Wellington

Tel: +64 9 574 1744

**SG – Singapore**

Tel: +65 6887 6300

**TH – Thailand,** Bangkok

Tel: +662 717 8140

**TW – Taiwan,** New Taipei City

Tel: +886 2 2298 8987

## South America

**AR – Argentina,** Buenos Aires

Tel: +54 3327 44 4129

**BR – Brazil,** Cachoeirinha RS

Tel: +55 51 3470 9144

**CL – Chile,** Santiago

Tel: +56 2 623 1216

**Pan Am,** Miami

Tel: +1 305-470-8800

## Parker-Hannifin Corporation

Chelsea Products Division  
8225 Hacks Cross Rd  
Olive Branch, MS 38654  
United States

Phone: +1 (662) 895-1011

Email: [chd\\_support@support.parker.com](mailto:chd_support@support.parker.com)

[www.Parker.com/Chelsea](http://www.Parker.com/Chelsea)

PN: HY25-1FRD-M1/US

Rev: 10/25

